

## Anúncio Convite

### Aquisição ao abrigo do Decreto-lei n.º 60/2018, de 3 de agosto

(Português)

<b>Referência (indicar na proposta):</b>	2023-57
<b>Entidade Adjudicante:</b>	UNINOVA – Instituto de Desenvolvimento de Novas Tecnologias PT501797173
<b>Projecto:</b>	ADVISION
<b>Data da Publicação:</b>	2023-06-12
<b>Prazo final da proposta:</b>	3 dias uteis após a data da publicação
<b>Objeto do contrato:</b>	Fornecimento e montagem de peças de alumínio maquinadas para afinação do suporte de um robot para apoio à investigação
<b>Características Técnicas:</b>	Descritas nos Desenhos Fornecidos
<b>Critério de Adjudicação:</b>	Critério da proposta economicamente mais vantajosa na modalidade monofactor: Preço
<b>Critério de desempate:</b>	Nos termos da alínea c), do n.º 5 do artigo 74.º do CCP, em caso de empate, o sorteio, a desenrolar presencialmente com o júri do concurso e com os interessados, em data, hora e local a comunicar com a antecedência mínima de três dias, do qual será lavrada ata por todos os presentes
<b>Preço base (sem IVA):</b>	800€ (Oitocentos Euros)
<b>Condições de pagamento:</b>	60 dias após a data de emissão da fatura.
<b>Condições de faturação:</b>	Submissão na plataforma de faturação eletrónica iLINK.
<b>Enviar proposta para:</b>	<a href="mailto:compras@uninova.pt">compras@uninova.pt</a> e <a href="mailto:jab@uninova.pt">jab@uninova.pt</a>
<b>Responsável pela avaliação de propostas:</b>	José António Barata de Oliveira
<b>Gestor do Contrato:</b>	José António Barata de Oliveira
<b>Audiência prévia:</b>	3 dias úteis após data notificação da proposta de adjudicação
<b>ANEXOS</b>	<b>Anexo I – Desenhos em formato PDF e DXF</b>

## **Invitation Announcement**

### **Acquisition under Decree-Law n.º 60/2018, of 3 de August**

(English)

<b>Reference (indicate in the proposal):</b>	2023-57
<b>Contracting Authority:</b>	UNINOVA – Instituto de Desenvolvimento de Novas Tecnologias PT501797173
<b>Project:</b>	ADVISION
<b>Publication Date:</b>	2023-06-12
<b>Proposal Deadline:</b>	3 business days after the publication date
<b>Subject of the contract:</b>	Supply and assembly of machined aluminum parts for tuning the support of a robot to support research
<b>Technical Characteristics:</b>	PDF and DXF format drawing Attached
<b>Selection criteria:</b>	Criteria of the most economically advantageous proposal in the single-factor modality: lowest price.
<b>Tiebreaker criteria:</b>	Under the terms of subparagraph c), of paragraph 5 of article 74 of the CCP, in the event of a tie, the draw, to be carried out in person with the competition jury and with the interested parties, on a date, time and place to be communicated with at least three days in advance, of which minutes will be drawn up by all those present.
<b>Base Price (VAT not included):</b>	800€ (Eight Hundred euros)
<b>Payment Conditions:</b>	60 days after invoice.
<b>Invoicing Conditions:</b>	Submission on the iLINK electronic invoicing platform
<b>Send proposals to:</b>	<a href="mailto:compras@uninova.pt">compras@uninova.pt</a> and <a href="mailto:jab@uninova.pt">jab@uninova.pt</a>
<b>Person in charge of proposals analysis:</b>	José António Barata de Oliveira
<b>Contract manager:</b>	José António Barata de Oliveira
<b>Prior hearing:</b>	3 business days from the date of notification of award proposal
<b>Annex:</b>	Annex I - PDF and DXF format drawing Attached

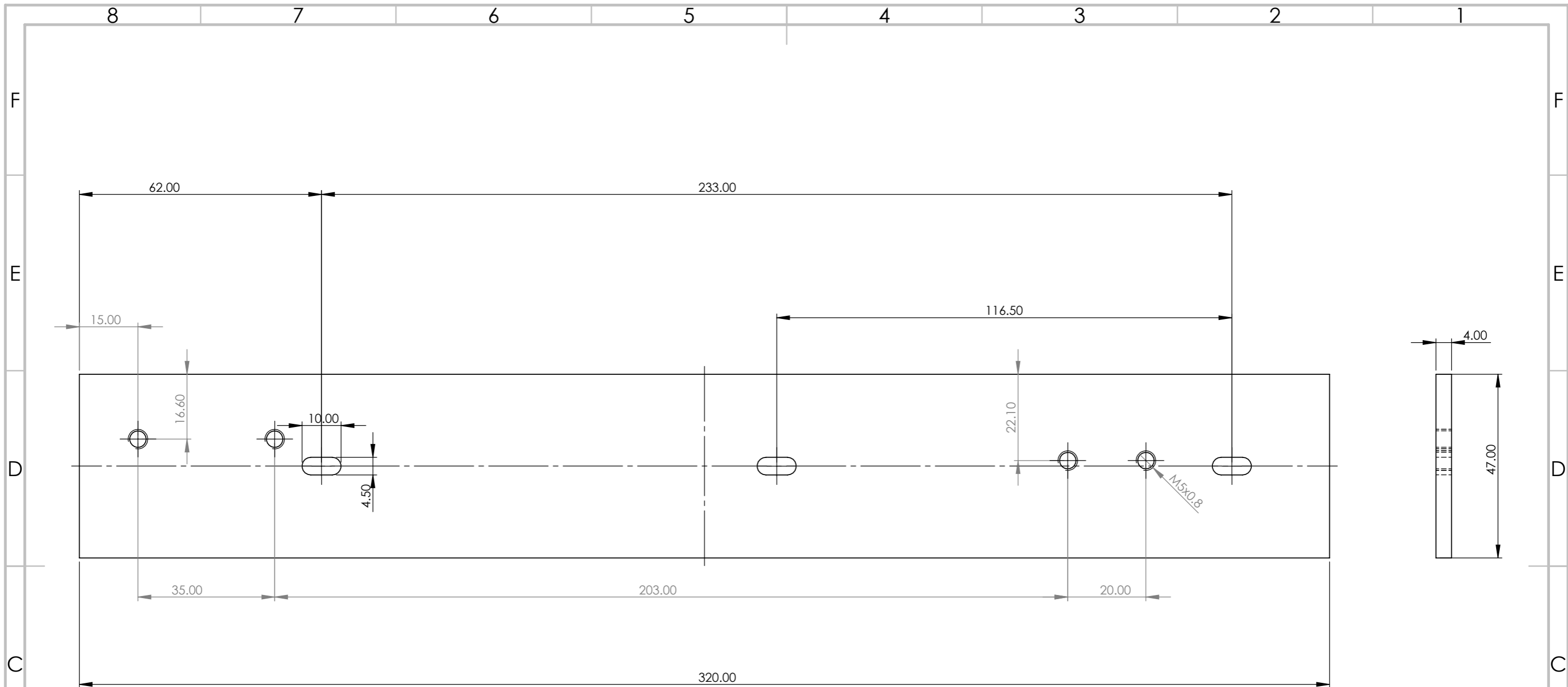

8 PEÇAS

UNLESS OTHERWISE SPECIFIED: DIMENSIONS ARE IN MILLIMETERS SURFACE FINISH: TOLERANCES: LINEAR: ANGULAR:			FINISH:		DEBURR AND BREAK SHARP EDGES		DO NOT SCALE DRAWING		REVISION	
							Last saved		10/05/2023	
							TITLE:		Base de Montagem	
							Default			
DRAWN			NAME		SIGNATURE		DATE		DWG NO.	
CHK'D									BA-01	
APPV'D									A3	
MFG									SCALE:1:2	
Q.A									SHEET 1 OF 1	
					MATERIAL: Ch Aço 1.0037 (S235JR)					
					WEIGHT:					

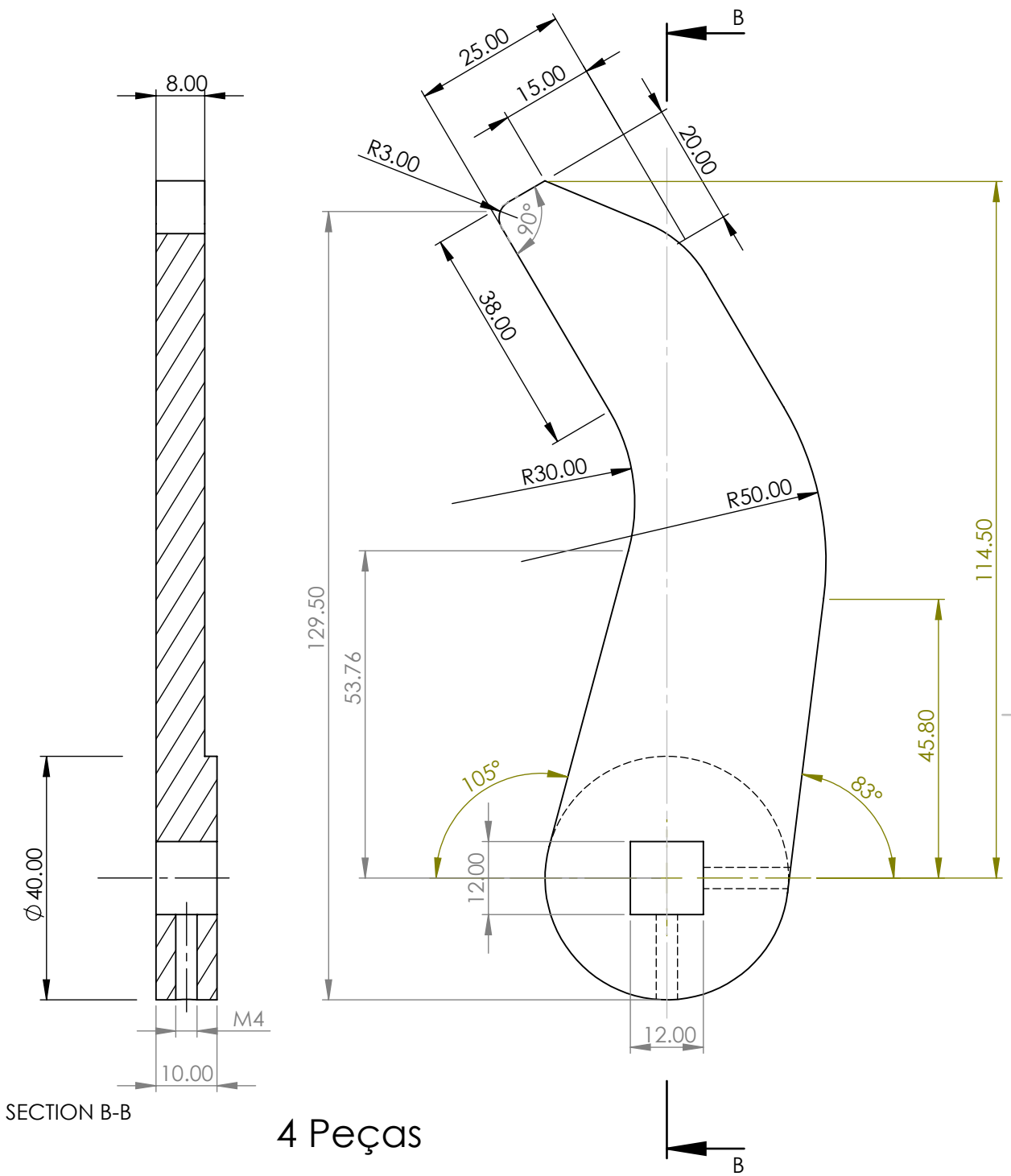

4 Peças

UNLESS OTHERWISE SPECIFIED:  
 DIMENSIONS ARE IN MILLIMETERS  
 SURFACE FINISH:  
 TOLERANCES:  
 LINEAR:  
 ANGULAR:

FINISH:

DEBURR AND  
 BREAK SHARP  
 EDGES

DO NOT SCALE DRAWING

REVISION

Last saved

10/05/2023

	NAME	SIGNATURE	DATE
DRAWN	Pamies Teixeira		
CHK'D			
APPV'D			
MFG			
Q.A			

TITLE:	Biela Mandada Direita	
DWG NO.	BM-02	A4
SCALE:1:1	SHEET 1 OF 1	

MATERIAL:  
2024 Alloy

WEIGHT:

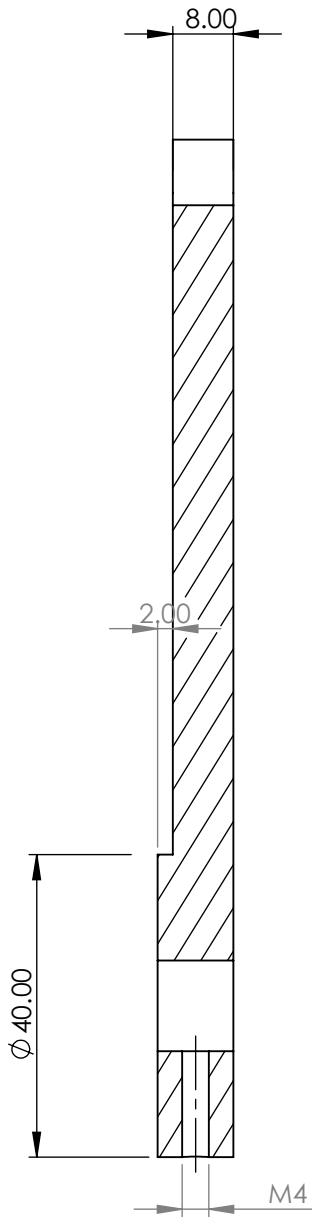

SECTION B-B

4 Peças

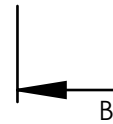
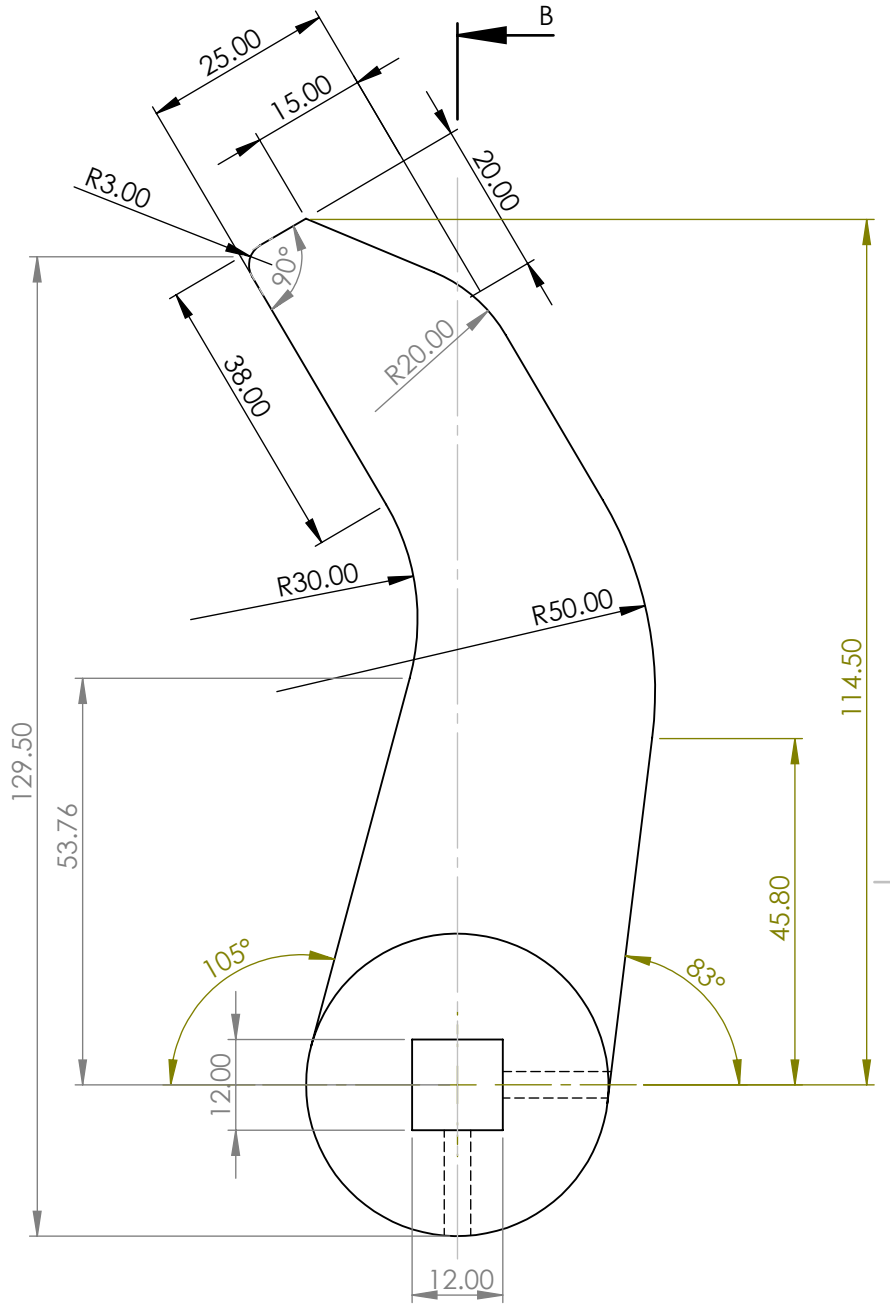

UNLESS OTHERWISE SPECIFIED:  
DIMENSIONS ARE IN MILLIMETERS  
SURFACE FINISH:  
TOLERANCES:  
LINEAR:  
ANGULAR:

FINISH:

DEBURR AND  
BREAK SHARP  
EDGES

DO NOT SCALE DRAWING

REVISION

Last saved

10/05/2023

	NAME	SIGNATURE	DATE
DRAWN	Pamies Teixeira		
CHK'D			
APPV'D			
MFG			
Q.A			

TITLE:	Biela Mandada	
	Esquerda	
DWG NO.	BM-02	A4
SCALE:1:1	SHEET 1 OF 1	

MATERIAL:  
2024-T3

WEIGHT:

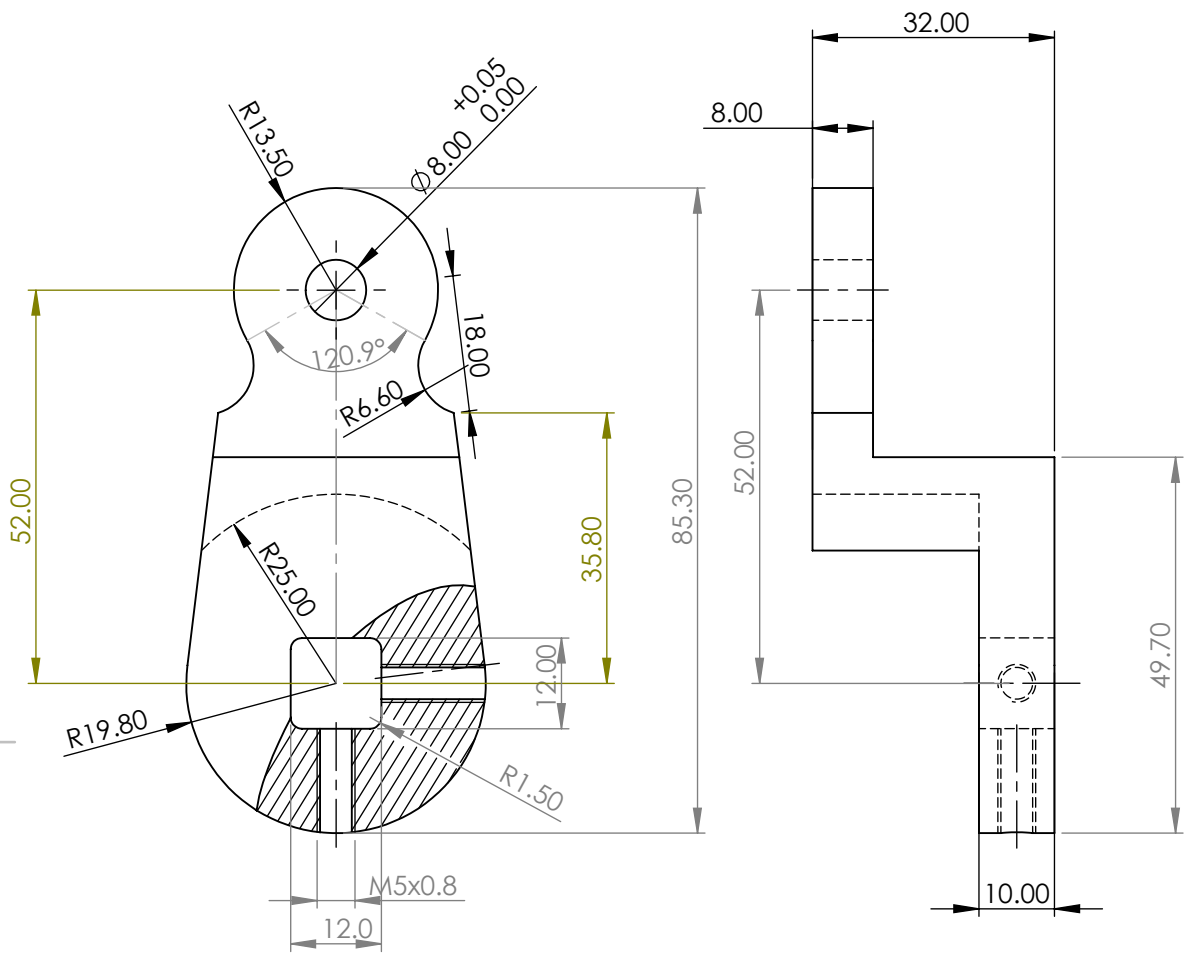

8 Peças p/ Mesa Grande  
4 Peças p/ Mesa Pequena

UNLESS OTHERWISE SPECIFIED:  
DIMENSIONS ARE IN MILLIMETERS  
SURFACE FINISH:  
TOLERANCES:  
LINEAR:  
ANGULAR:

FINISH:

DEBURR AND  
BREAK SHARP  
EDGES

DO NOT SCALE DRAWING

REVISION

Last saved

11/05/2023

	NAME	SIGNATURE	DATE
DRAWN	Pamies Teixeira		
CHK'D			
APPV'D			
MFG			
Q.A			

TITLE:		Biela Mandante	
MATERIAL:		2024-T3	
DWG NO.:		BD-01	
WEIGHT:		SCALE:1:1	
		SHEET 1 OF 1	

A4

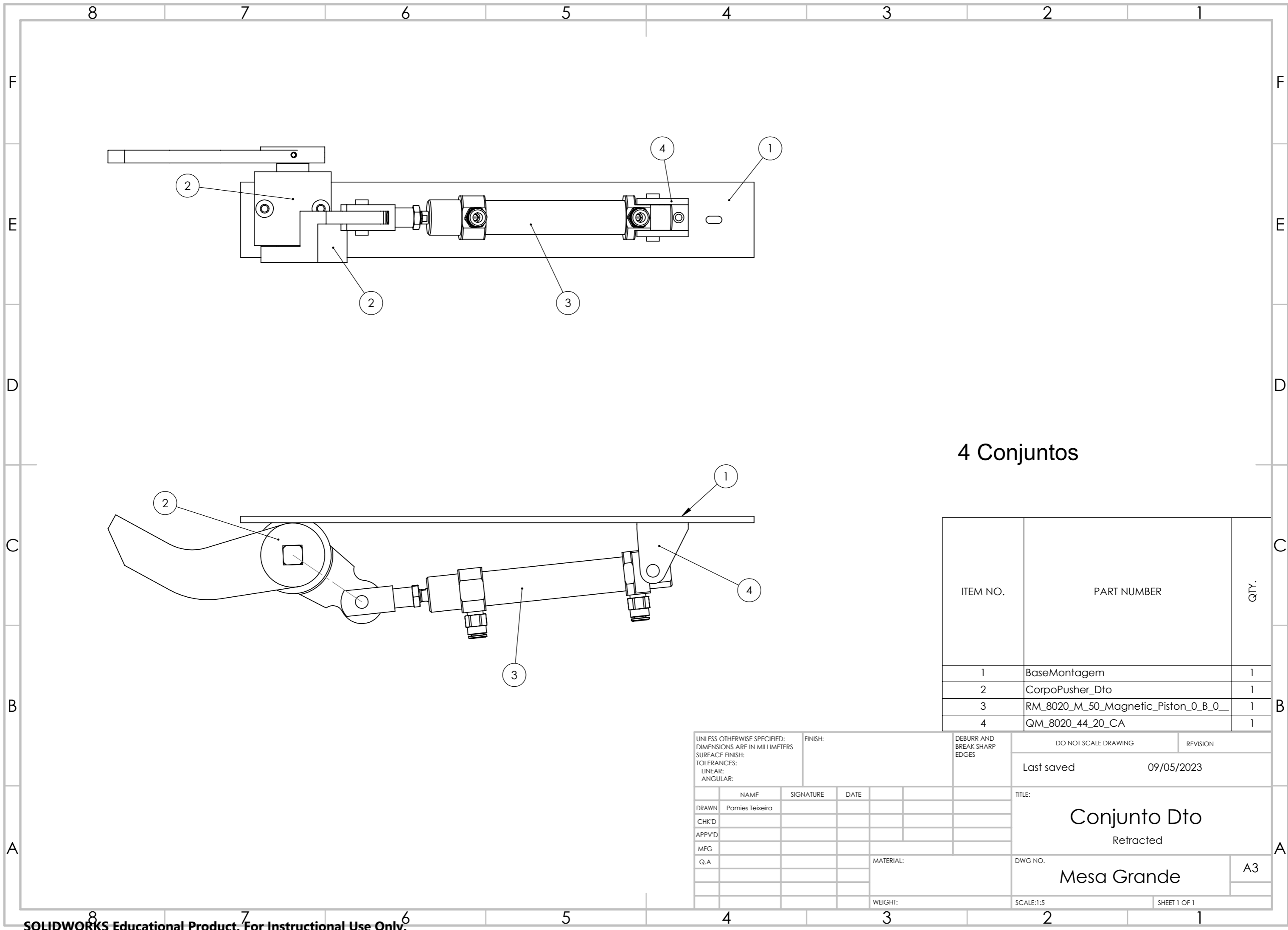

4 Conjuntos

ITEM NO.	PART NUMBER	QTY.
1	BaseMontagem	1
2	CorpoPusher_Dto	1
3	RM_8020_M_50_Magnetic_Piston_0_B_0_	1
4	QM_8020_44_20_CA	1

UNLESS OTHERWISE SPECIFIED: DIMENSIONS ARE IN MILLIMETERS SURFACE FINISH: TOLERANCES: LINEAR: ANGULAR:			FINISH:		DEBURR AND BREAK SHARP EDGES		DO NOT SCALE DRAWING		REVISION	
							Last saved		09/05/2023	
							TITLE:		Conjunto Dto	
									Retracted	
							DWG NO.		A3	
							SCALE:1:5		SHEET 1 OF 1	

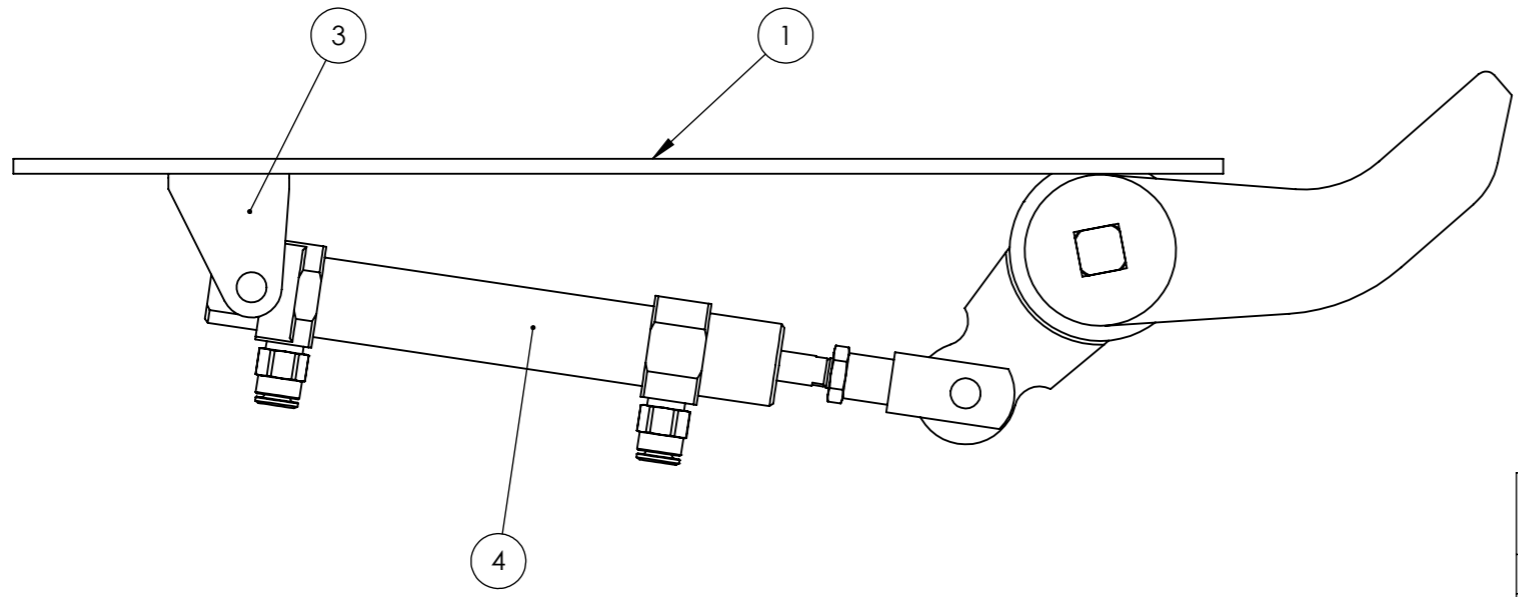
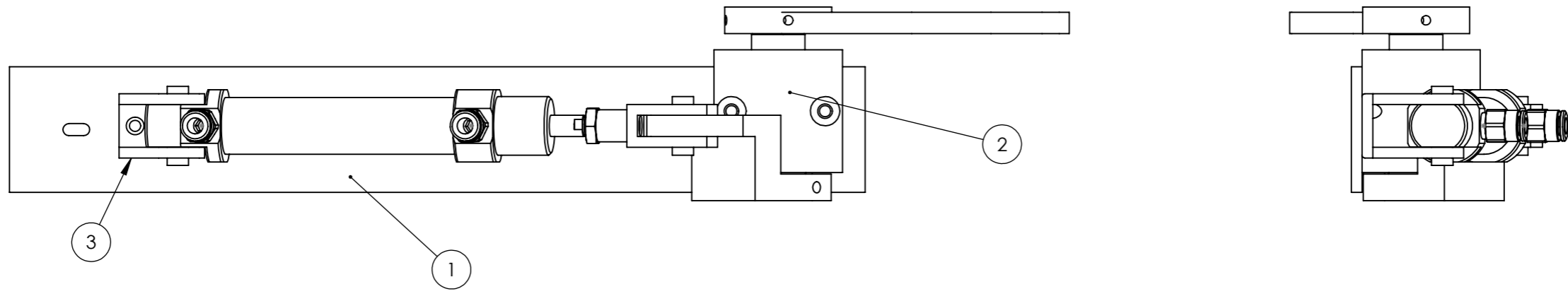

4 Conjuntos

ITEM NO.	PART NUMBER	QTY.
1	BaseMontagem	1
2	CorpoPusher_Esq	1
3	QM_8020_44_20_CA	1
4	RM_8020_M_50_Magnetic_Piston_0_B_0_	1

UNLESS OTHERWISE SPECIFIED: DIMENSIONS ARE IN MILLIMETERS SURFACE FINISH: TOLERANCES: LINEAR: ANGULAR:			FINISH:		DEBURR AND BREAK SHARP EDGES		DO NOT SCALE DRAWING		REVISION		
							Last saved		10/05/2023		
							TITLE: <b>Conjunto Esq.</b> Default				
DRAWN Pamiés Teixeira			SIGNATURE		DATE		MATERIAL:		DWG NO.		
CHK'D									A3		
APPV'D											
MFG											
Q.A							WEIGHT:		SCALE:1:5		SHEET 1 OF 1



4 3 2 1

F

F

E

E

D

D

C

C

B

B

A

A

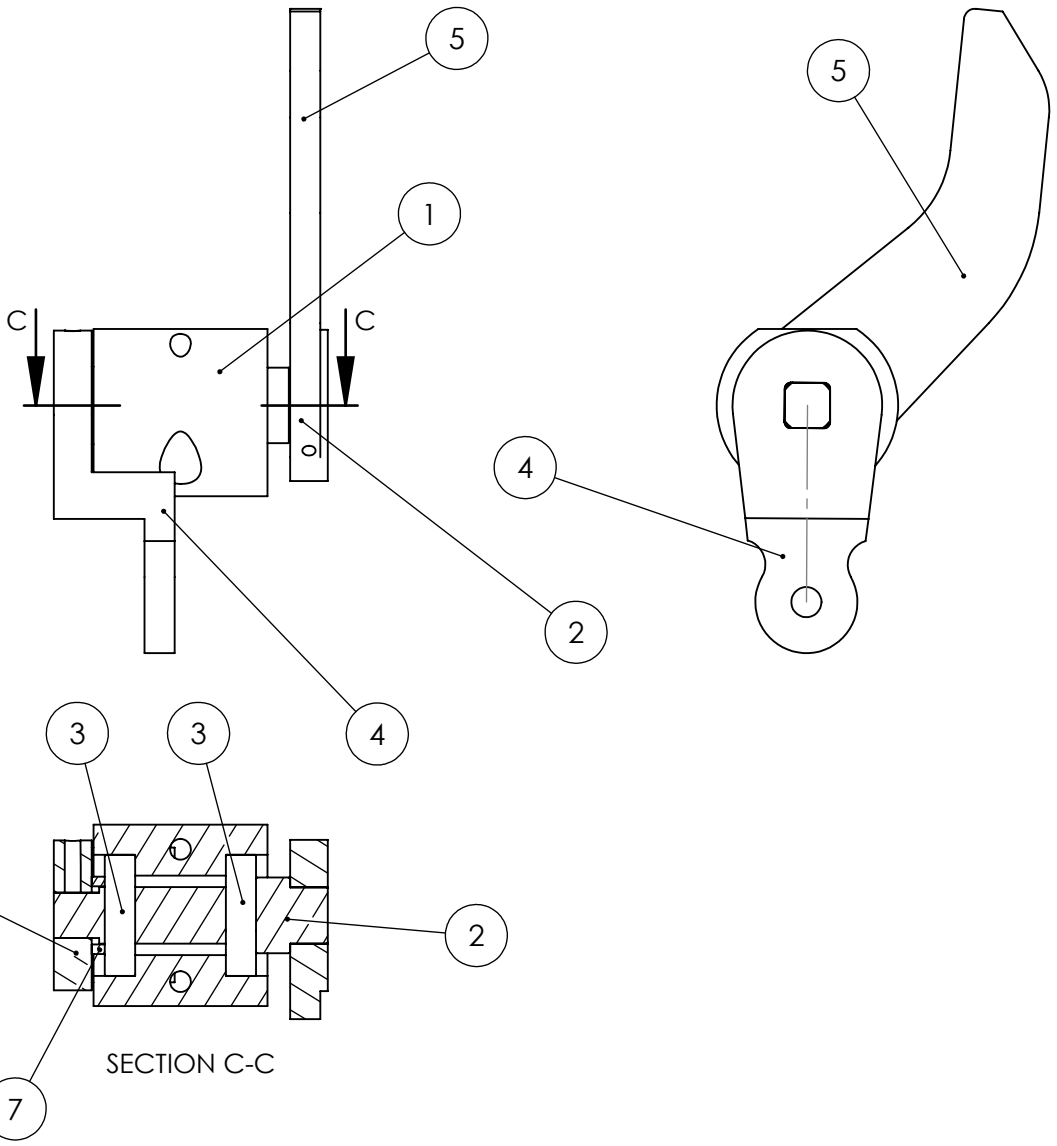

ITEM NO.	PART NUMBER	QTY.
1	Cubo_V3	1
2	Veio_V2-Dto	1
3	SKF - 16002 - 12,SI,NC,12_68	2
4	BielaMandante	1
5	BielaMandada_Dta	1
6	ISO 4028 - M5 x 10-N	1
7	Espaçador	1

UNLESS OTHERWISE SPECIFIED:  
 DIMENSIONS ARE IN MILLIMETERS  
 SURFACE FINISH:  
 TOLERANCES:  
 LINEAR:  
 ANGULAR:

FINISH:

DEBURR AND  
 BREAK SHARP  
 EDGES

DO NOT SCALE DRAWING

REVISION

Last saved 11/05/2023

	NAME	SIGNATURE	DATE
DRAWN			
CHK'D			
APPV'D			
MFG			
Q.A			

TITLE:  
**Corpo Pusher Direito**

MATERIAL:  
 DWG NO. A4

WEIGHT:  
 SCALE:1:2 SHEET 1 OF 1

4 3 2 1

F

F

E

E

D

D

C

C

B

B

A

A

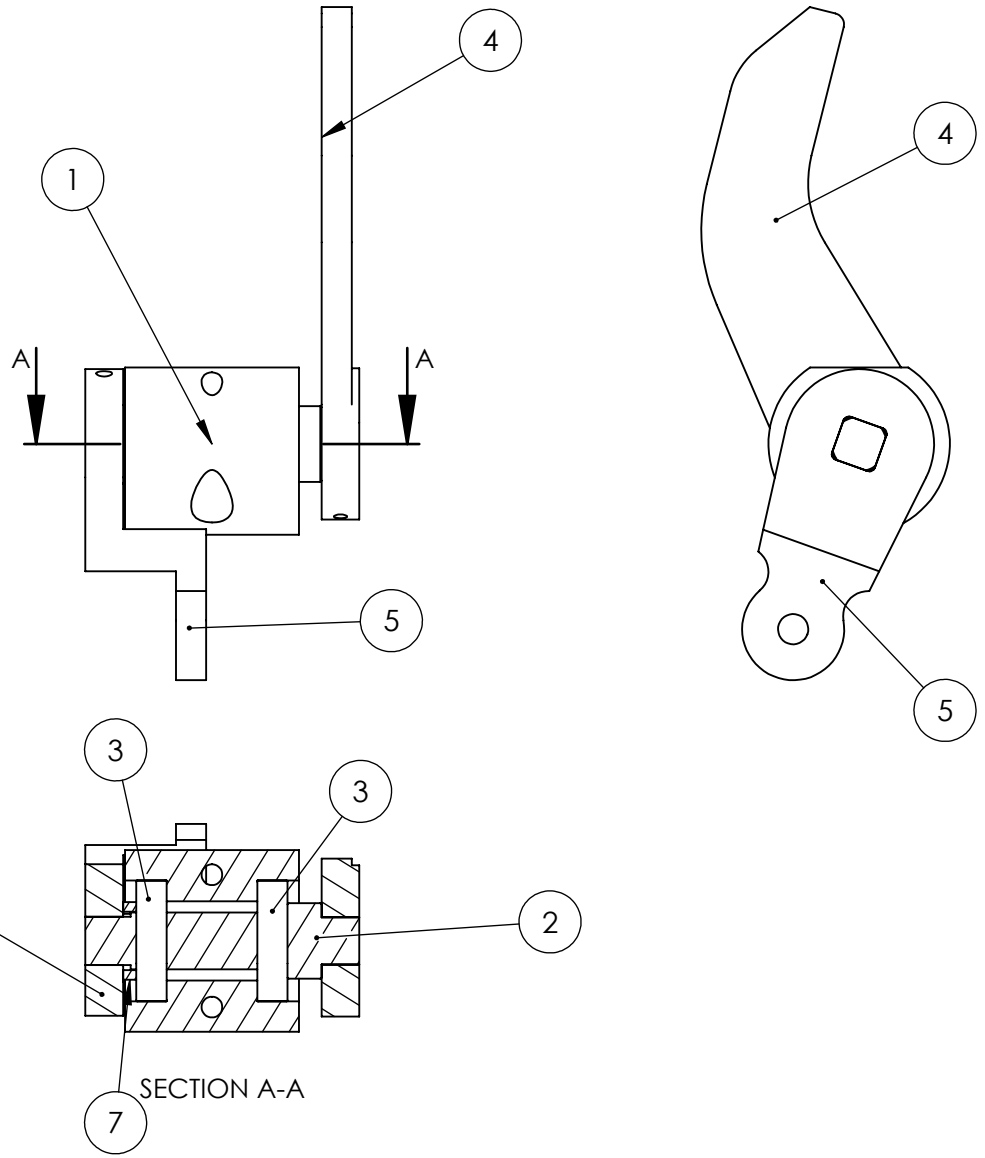

ITEM NO.	PART NUMBER	QTY.
1	Cubo_V3	1
2	Veio_V2-Esq	1
3	SKF - 16002 - 12,SI,NC,12_68	2
4	BielaMandada_Esq	1
5	BielaMandante	1
6	ISO 4028 - M5 x 10-N	1
7	Espaçador	1

UNLESS OTHERWISE SPECIFIED:  
 DIMENSIONS ARE IN MILLIMETERS  
 SURFACE FINISH:  
 TOLERANCES:  
 LINEAR:  
 ANGULAR:

FINISH:

DEBURR AND  
 BREAK SHARP  
 EDGES

DO NOT SCALE DRAWING  
 REVISION  
 Last saved 11/05/2023

NAME	SIGNATURE	DATE
DRAWN		
CHK'D		
APPV'D		
MFG		
Q.A		

TITLE:  
**Corpo Pusher Esquerdo**

MATERIAL:  
 DWG NO. A4

WEIGHT:  
 SCALE:1:2 SHEET 1 OF 1

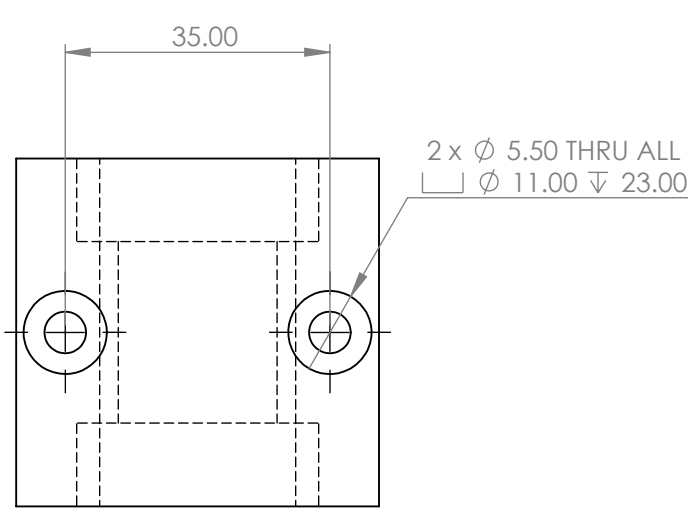
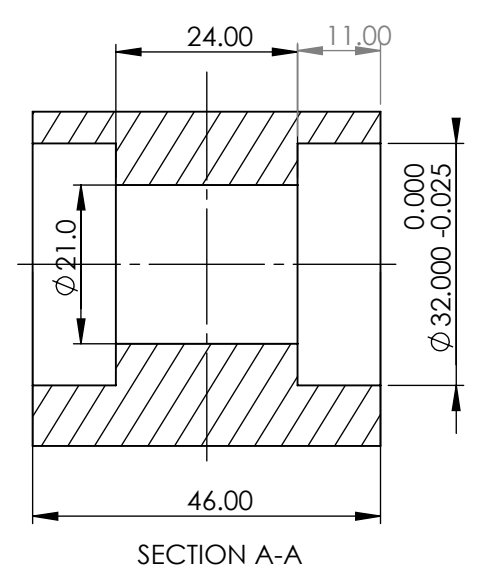
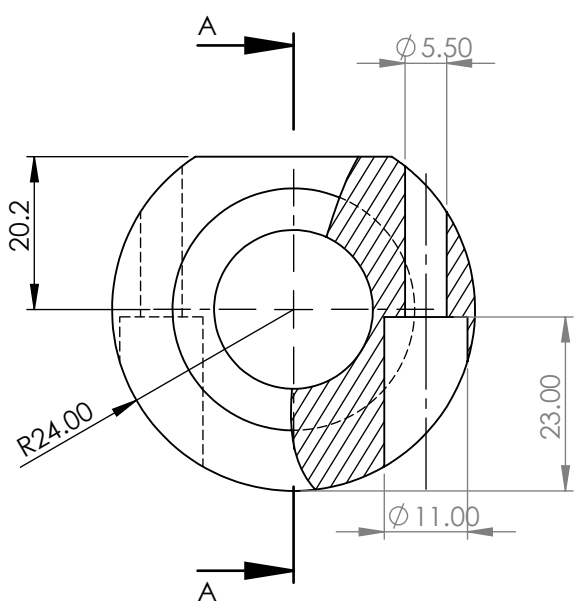

8 Peças p/ Mesa Grande  
4 Peças p/Mesa Pequena

UNLESS OTHERWISE SPECIFIED: DIMENSIONS ARE IN MILLIMETERS SURFACE FINISH: TOLERANCES: LINEAR: ANGULAR:			FINISH:	DEBURR AND BREAK SHARP EDGES	DO NOT SCALE DRAWING	REVISION
					Last saved	10/05/2023
NAME	SIGNATURE	DATE	TITLE: <b>Cubo</b>			
DRAWN Pamies Teixeira						
CHK'D						
APPV'D						
MFG						
Q.A			MATERIAL: 2024-T3	DWG NO. CB-01	A4	
			WEIGHT:	SCALE:1:1	SHEET 1 OF 1	

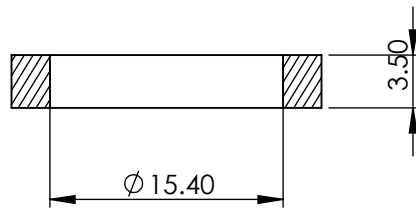
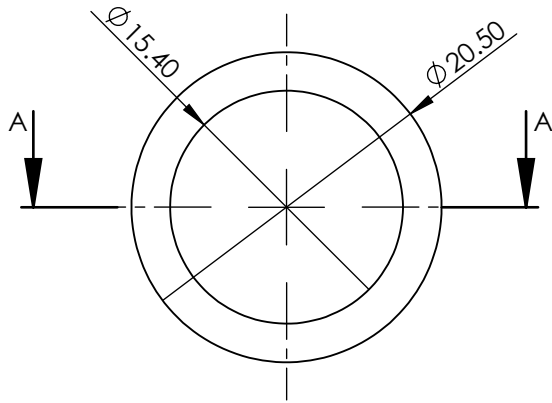

SECTION A-A

UNLESS OTHERWISE SPECIFIED: DIMENSIONS ARE IN MILLIMETERS SURFACE FINISH: TOLERANCES: LINEAR: ANGULAR:				FINISH:		DEBURR AND BREAK SHARP EDGES		DO NOT SCALE DRAWING		REVISION	
								Last saved		09/05/2023	
DRAWN						TITLE:  <b>Espaçador</b>					
CHK'D											
APPV'D											
MFG											
Q.A						MATERIAL:		DWG NO.		A4	
						Material <not specified>		E-01			
						WEIGHT:		SCALE:2:1		SHEET 1 OF 1	

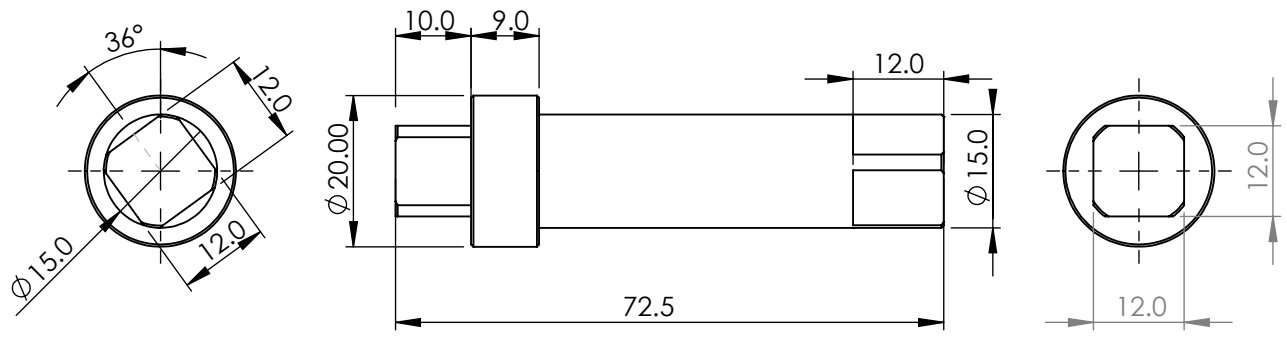

4 Peças

UNLESS OTHERWISE SPECIFIED: DIMENSIONS ARE IN MILLIMETERS SURFACE FINISH: TOLERANCES: LINEAR: ANGULAR:			FINISH:	DEBURR AND BREAK SHARP EDGES	DO NOT SCALE DRAWING	REVISION
					Last saved	10/05/2023
NAME	SIGNATURE	DATE	TITLE:			
DRAWN Pamies Teixeira			Veio Direito			
CHK'D						
APPV'D						
MFG						
Q.A			MATERIAL:	DWG NO.	A4	
			2024 Alloy	V-01		
			WEIGHT:	SCALE:1:1	SHEET 1 OF 1	

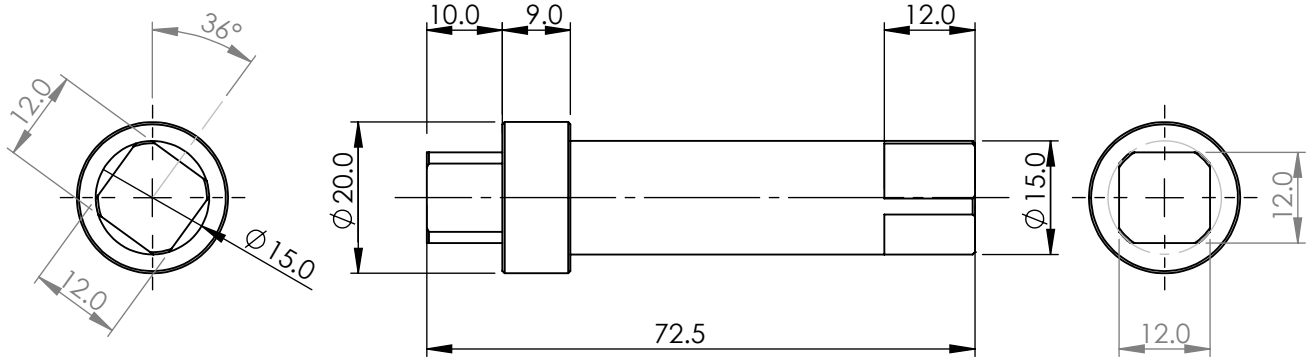

4 Peças

UNLESS OTHERWISE SPECIFIED: DIMENSIONS ARE IN MILLIMETERS SURFACE FINISH: TOLERANCES: LINEAR: ANGULAR:			FINISH:	DEBURR AND BREAK SHARP EDGES	DO NOT SCALE DRAWING	REVISION
					Last saved	10/05/2023
NAME	SIGNATURE	DATE	TITLE:			
DRAWN Pamies Teixeira			Veio Esquerdo			
CHK'D						
APPV'D						
MFG						
Q.A			MATERIAL:	DWG NO.	A4	
			2024 Alloy	V-02		
			WEIGHT:	SCALE:1:1	SHEET 1 OF 1	

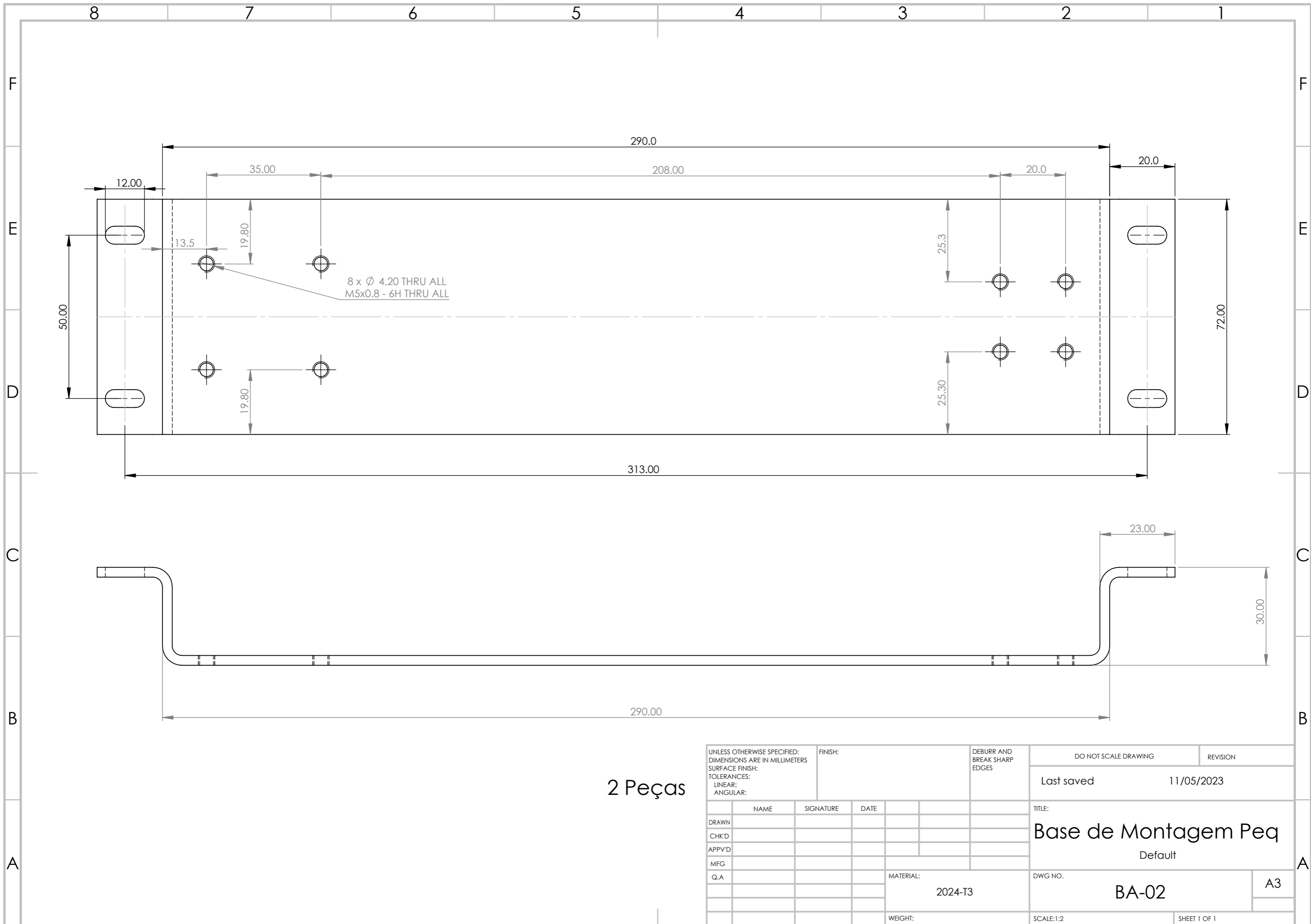

8 x Ø 4.20 THRU ALL  
M5x0.8 - 6H THRU ALL

2 Peças

UNLESS OTHERWISE SPECIFIED: DIMENSIONS ARE IN MILLIMETERS SURFACE FINISH: TOLERANCES: LINEAR: ANGULAR:			FINISH:		DEBURR AND BREAK SHARP EDGES		DO NOT SCALE DRAWING		REVISION	
							Last saved		11/05/2023	
							TITLE:		Base de Montagem Peq	
							Default			
					MATERIAL:		DWG NO.		A3	
					2024-T3		BA-02			
					WEIGHT:		SCALE:1:2		SHEET 1 OF 1	

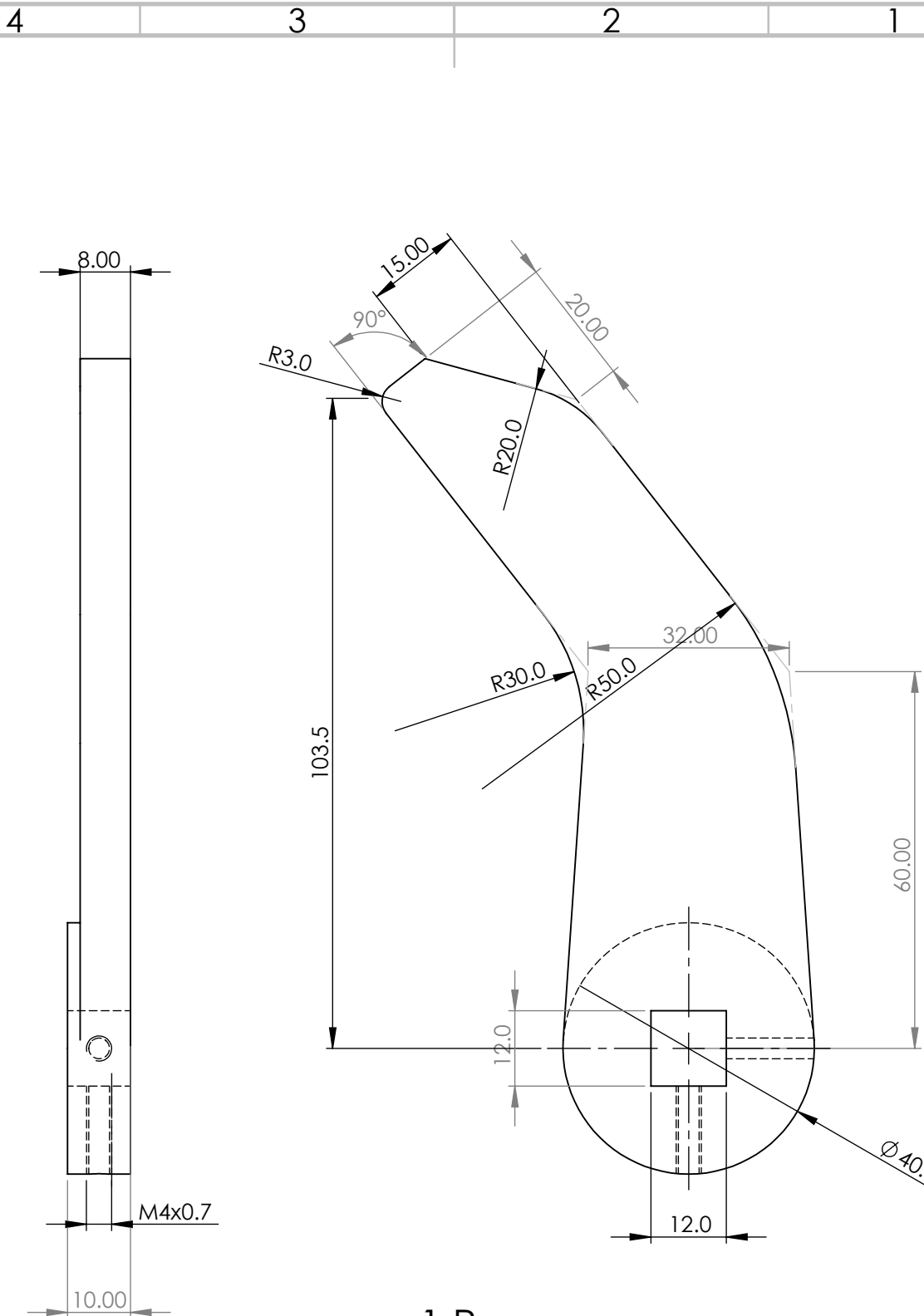

1 Peça

UNLESS OTHERWISE SPECIFIED:  
 DIMENSIONS ARE IN MILLIMETERS  
 SURFACE FINISH:  
 TOLERANCES:  
 LINEAR:  
 ANGULAR:

FINISH:

DEBURR AND  
 BREAK SHARP  
 EDGES

DO NOT SCALE DRAWING

REVISION

Last saved

09/05/2023

	NAME	SIGNATURE	DATE
DRAWN	Pamies Teixeira		
CHK'D			
APPV'D			
MFG			
Q.A			

TITLE:	
Biela Mandada Peça Direita	
DWG NO.	BM-02
	A4
WEIGHT:	SCALE:1:1
	SHEET 1 OF 1



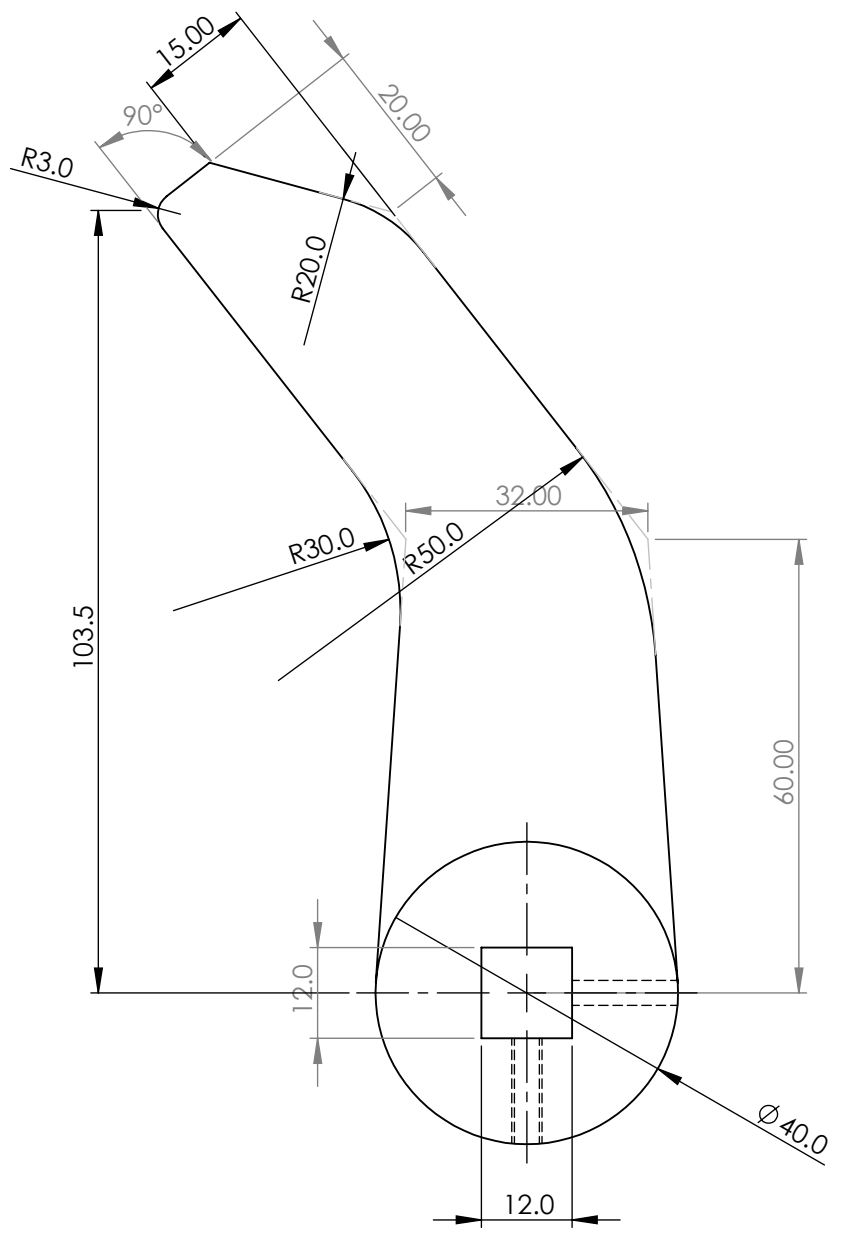
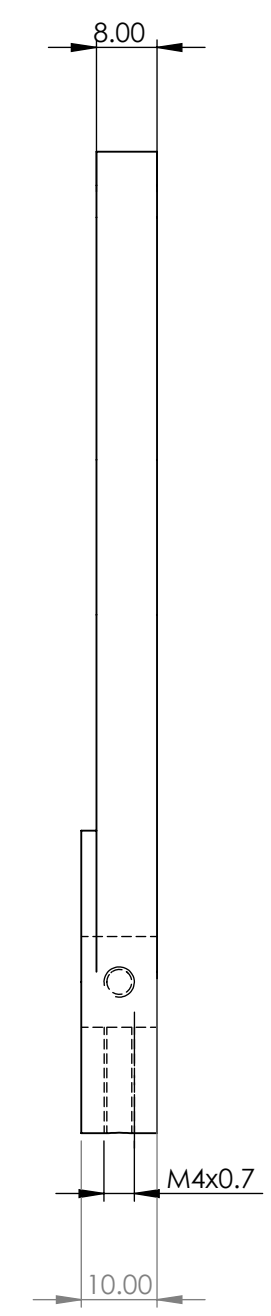

1 Peça

UNLESS OTHERWISE SPECIFIED: DIMENSIONS ARE IN MILLIMETERS SURFACE FINISH: TOLERANCES: LINEAR: ANGULAR:			FINISH:	DEBURR AND BREAK SHARP EDGES	DO NOT SCALE DRAWING	REVISION
					Last saved	09/05/2023
NAME	SIGNATURE	DATE	TITLE:			
DRAWN Pamies Teixeira			Biela Mandada Peq			
CHK'D			Esquerda			
APPV'D			MATERIAL:			
MFG			Material <not specified>		DWG NO.	A4
Q.A			WEIGHT:		SCALE:1:1	SHEET 1 OF 1

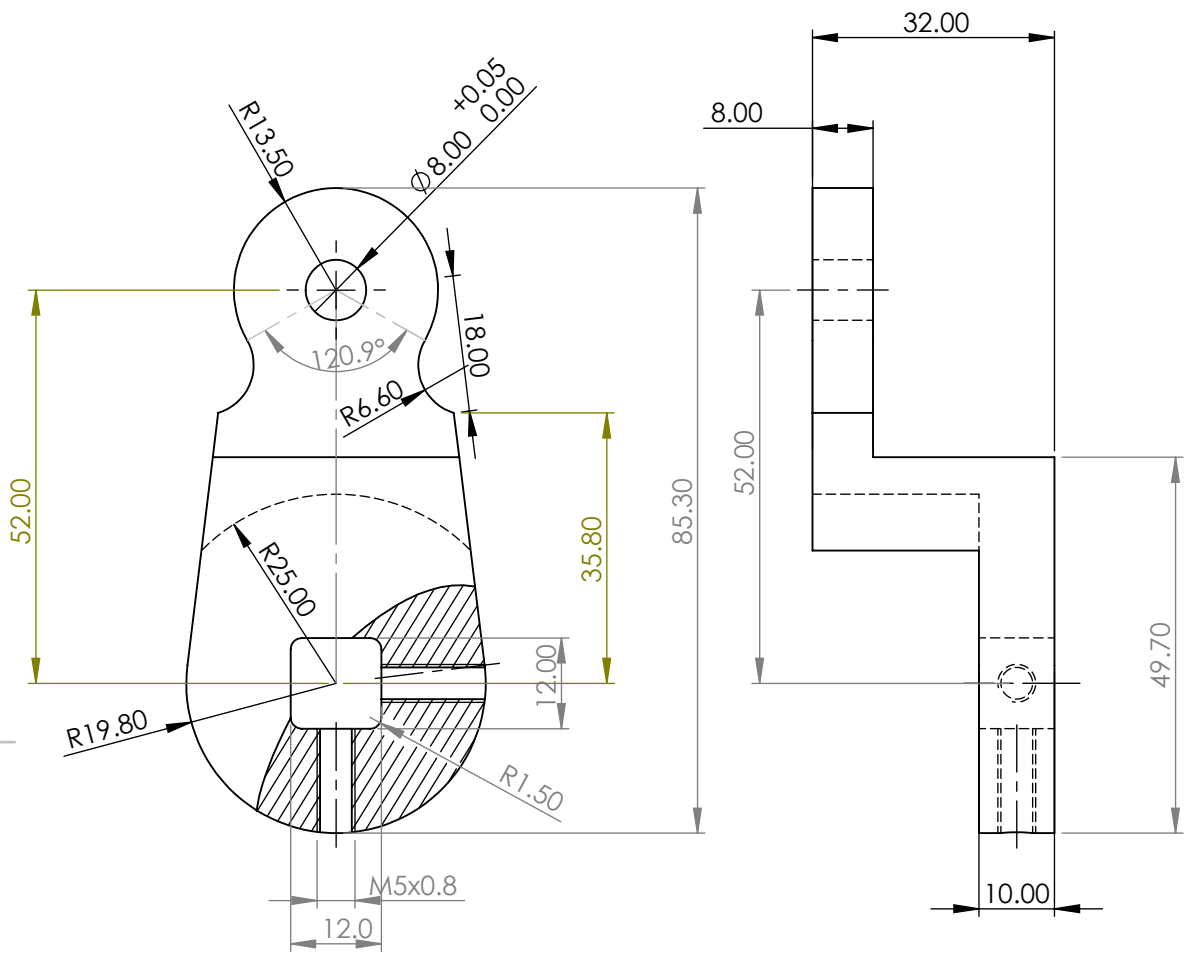

8 Peças p/ Mesa Grande  
4 Peças p/ Mesa Pequena

UNLESS OTHERWISE SPECIFIED:  
DIMENSIONS ARE IN MILLIMETERS  
SURFACE FINISH:  
TOLERANCES:  
LINEAR:  
ANGULAR:

FINISH:

DEBURR AND  
BREAK SHARP  
EDGES

DO NOT SCALE DRAWING

REVISION

Last saved

11/05/2023

	NAME	SIGNATURE	DATE
DRAWN	Pamies Teixeira		
CHK'D			
APPV'D			
MFG			
Q.A			

TITLE:		Biela Mandante	
MATERIAL:		2024-T3	
DWG NO.:		BD-01	
WEIGHT:		SCALE:1:1	
		SHEET 1 OF 1	

A4

# Conjunto Mesa Pequena (Longitudinal)

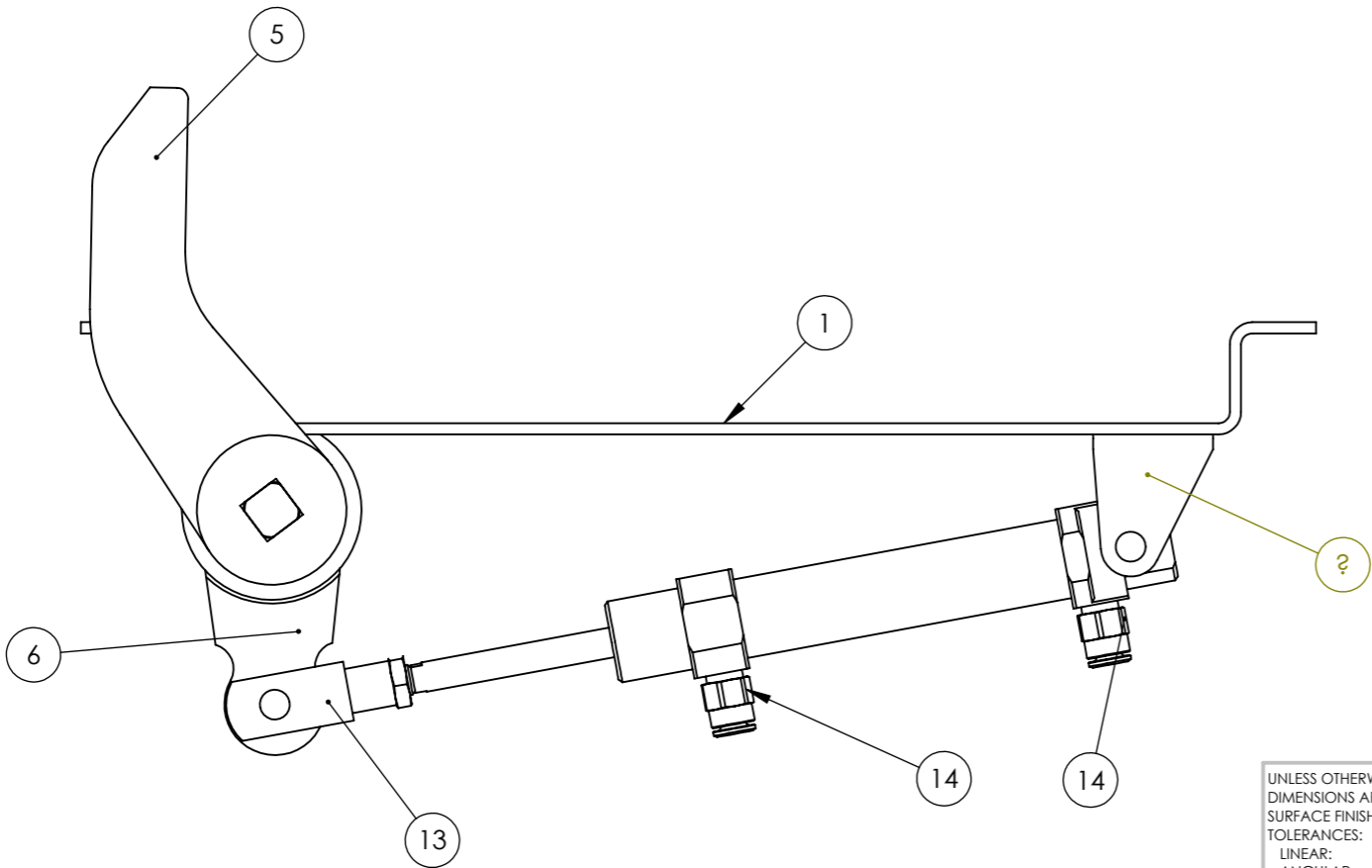
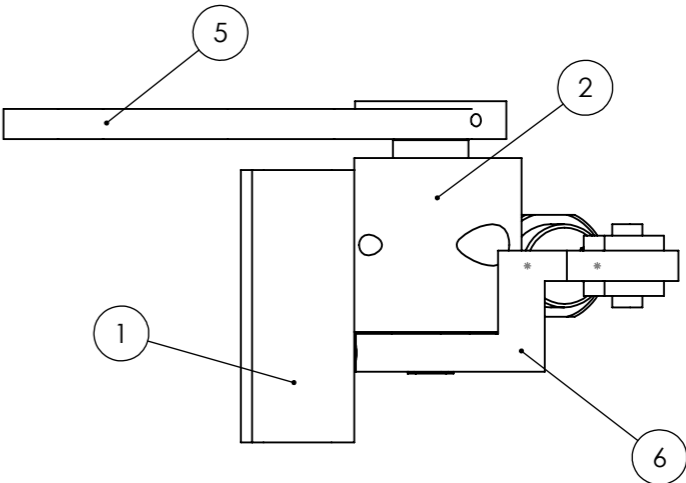
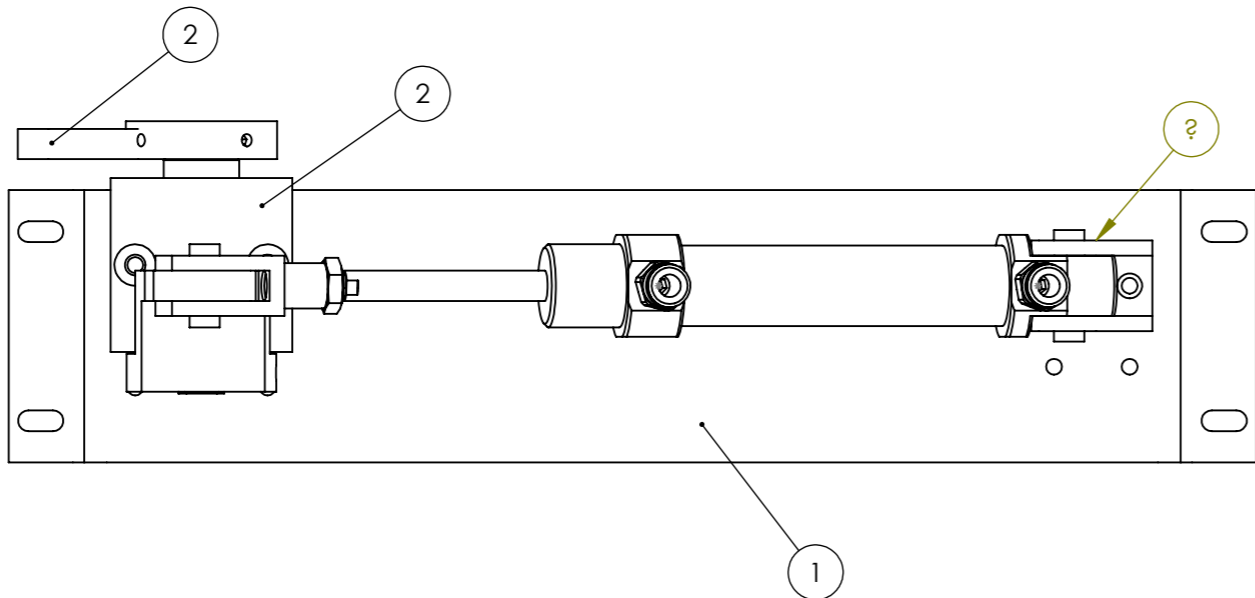

1 Conjunto

ITEM NO.	PART NUMBER	QTY.
1	Base_Montagem_P	1
2	CorpoPusher_Dto_Peq	1
3	RM_8020_M_50_Magnetic_Piston_0_B_0_	1
4	QM_8020_44	1

UNLESS OTHERWISE SPECIFIED: DIMENSIONS ARE IN MILLIMETERS SURFACE FINISH: TOLERANCES: LINEAR: ANGULAR:		FINISH:	DEBURR AND BREAK SHARP EDGES		DO NOT SCALE DRAWING	REVISION
					Last saved	11/05/2023
					TITLE: <b>Conunto Direito Peq</b> Extended	
					DWG NO. <b>PD-002</b>	A3
					SCALE:1:2	SHEET 1 OF 1

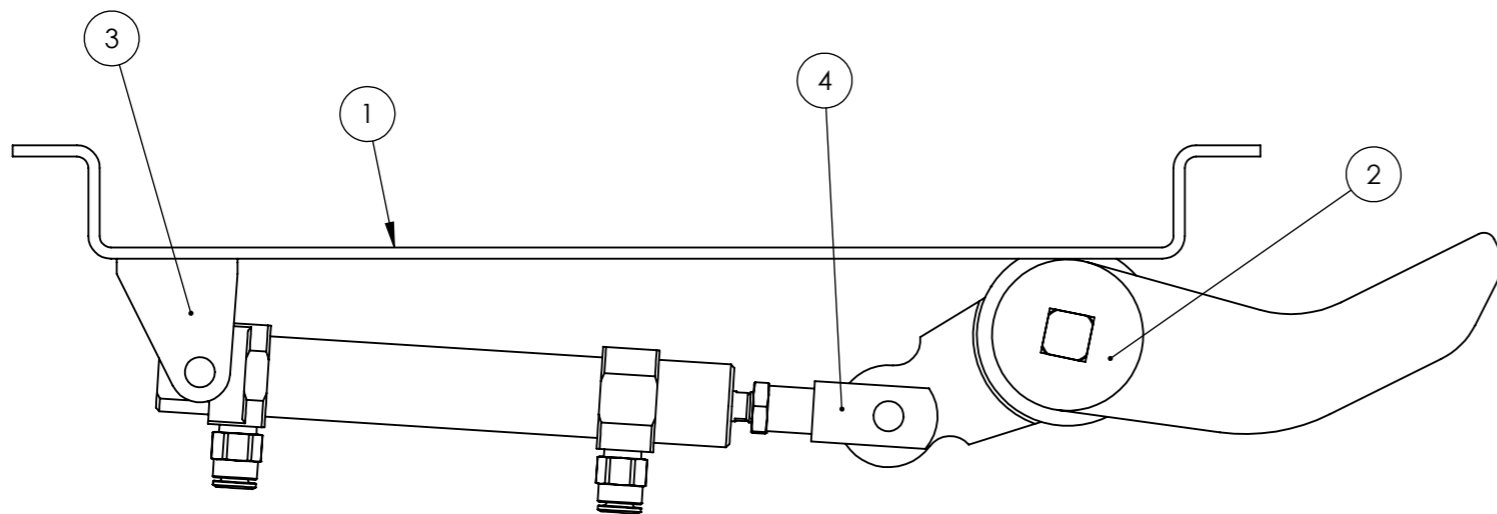
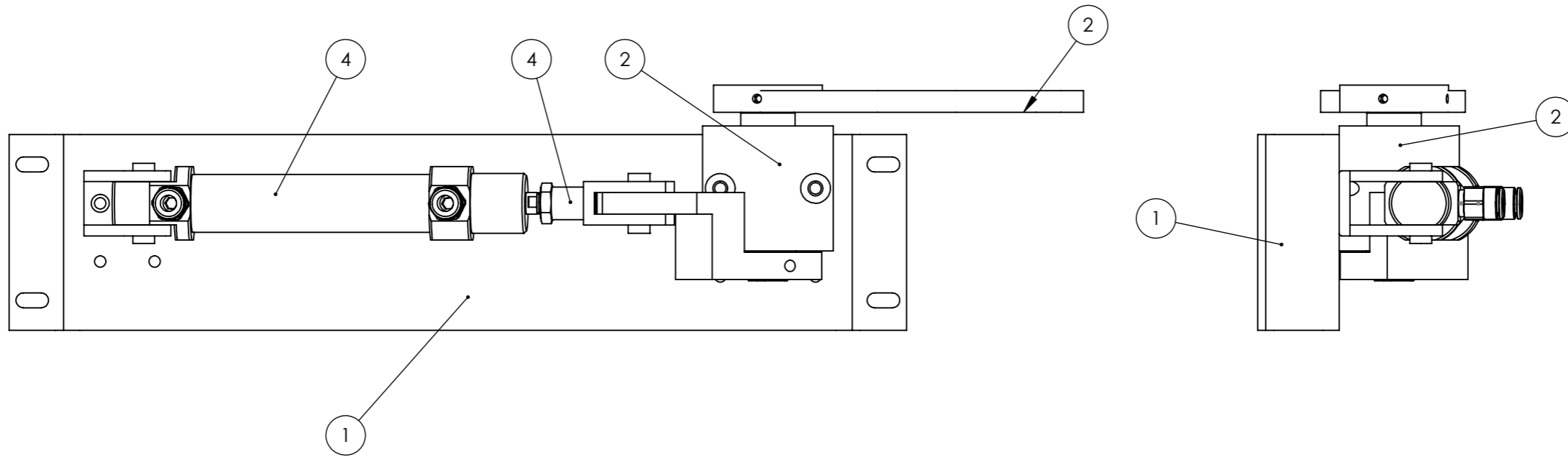

1 Conjunto

ITEM NO.	PART NUMBER	QTY.
1	Base_Montagem_P	1
2	CorpoPusher_Esq_Peq	1
3	QM_8020_44_20_CA	1
4	RM_8020_M_50_Magnetic_Piston_0_B_0_	1

UNLESS OTHERWISE SPECIFIED: DIMENSIONS ARE IN MILLIMETERS SURFACE FINISH: TOLERANCES: LINEAR: ANGULAR:			FINISH:		DEBURR AND BREAK SHARP EDGES		DO NOT SCALE DRAWING		REVISION	
							Last saved		11/05/2023	
DRAWN			NAME		SIGNATURE		DATE		TITLE:	
CHK'D									Cojunto Esquerdo Peq	
APPV'D									Default	
MFG									DWG NO.	
Q.A									A3	
							MATERIAL:		SCALE:1:5	
							WEIGHT:		SHEET 1 OF 1	

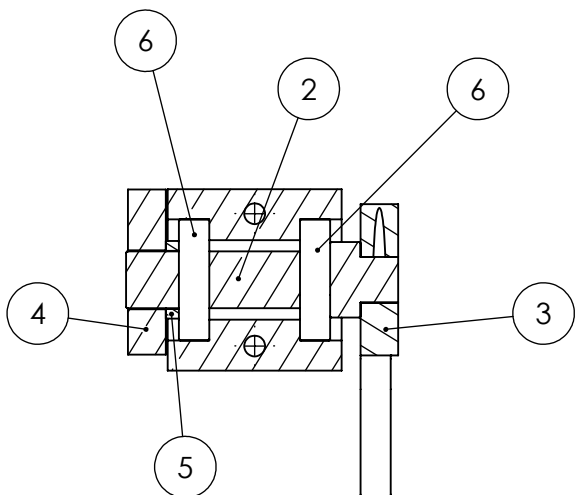
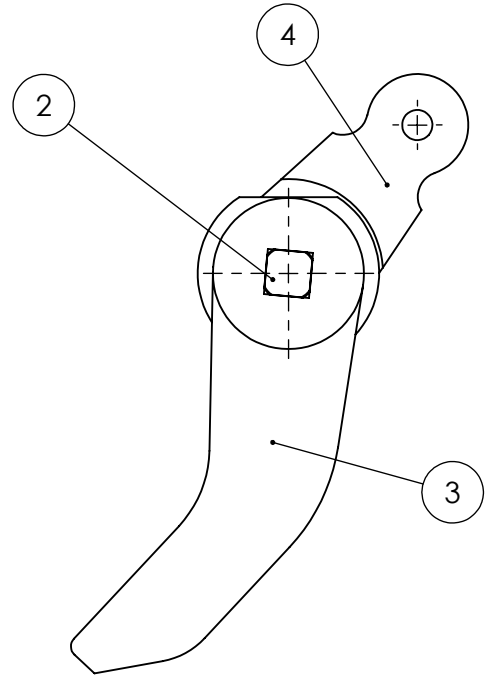
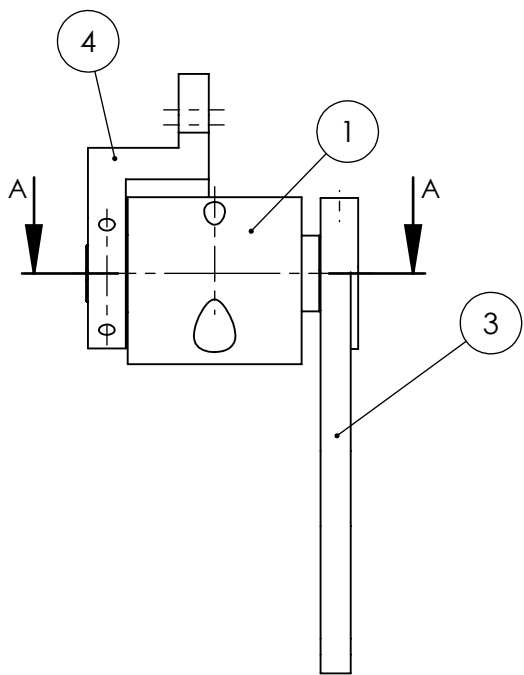

SECTION A-A

1 Conjunto

ITEM NO.	PART NUMBER	QTY.
1	Cubo_V3	1
2	Veio_P-Dto	1
3	BielaMandada_Peq_Mod	1
4	BielaMandante	1
5	Espaçador	1
6	SKF - 16002 - 12,SI,NC,12_68	2

UNLESS OTHERWISE SPECIFIED:  
 DIMENSIONS ARE IN MILLIMETERS  
 SURFACE FINISH:  
 TOLERANCES:  
 LINEAR:  
 ANGULAR:

FINISH:

DEBURR AND  
 BREAK SHARP  
 EDGES

DO NOT SCALE DRAWING

REVISION

Last saved

11/05/2023

	NAME	SIGNATURE	DATE
DRAWN			
CHK'D			
APPV'D			
MFG			
Q.A			

TITLE:		Corpo Pusher Dto
MATERIAL:		
DWG NO.		A4
WEIGHT:		SCALE:1:2
		SHEET 1 OF 1

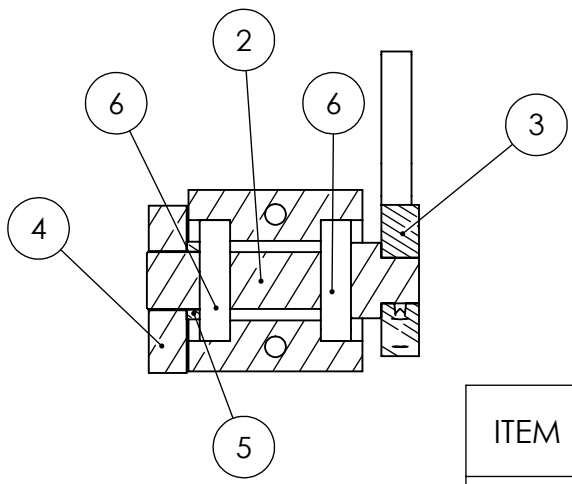
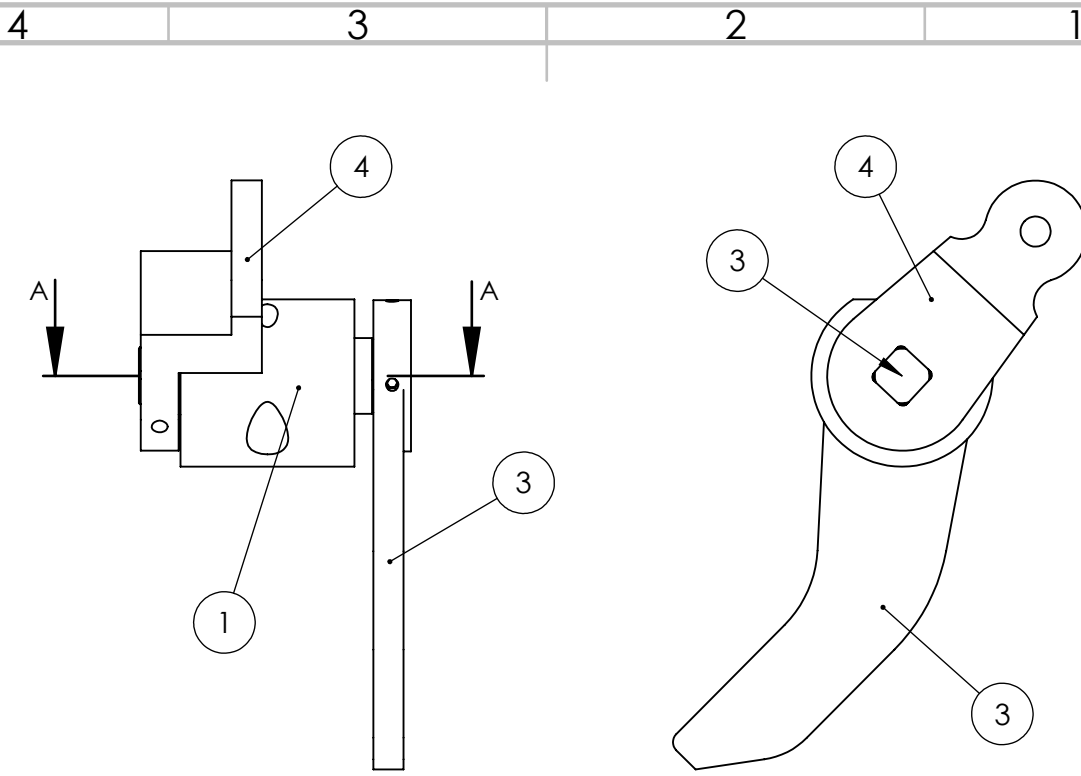

SECTION A-A

1 Conjunto

ITEM NO.	PART NUMBER	QTY.
1	Cubo_V3	1
2	Veio_P-Esq	1
3	BielaMandada_Peq_Mod	1
4	BielaMandante	1
5	Espaçador	1
6	SKF - 16002 - 12,SI,NC,12_68	2
7	ISO 4028 - M5 x 12-N	1
8	ISO 4028 - M5 x 10-N	1
9	ISO 4027 - M5 x 10-N	1

UNLESS OTHERWISE SPECIFIED:  
 DIMENSIONS ARE IN MILLIMETERS  
 SURFACE FINISH:  
 TOLERANCES:  
 LINEAR:  
 ANGULAR:

FINISH:  
  
 DEBURR AND  
 BREAK SHARP  
 EDGES

DO NOT SCALE DRAWING  
 REVISION  
 Last saved  
 11/05/2023

	NAME	SIGNATURE	DATE
DRAWN			
CHK'D			
APPV'D			
MFG			
Q.A			

TITLE:  
**Corpo Pusher Esq-Peq**  
  
 DWG NO.  
 A4  
  
 SCALE:1:2  
 SHEET 1 OF 1

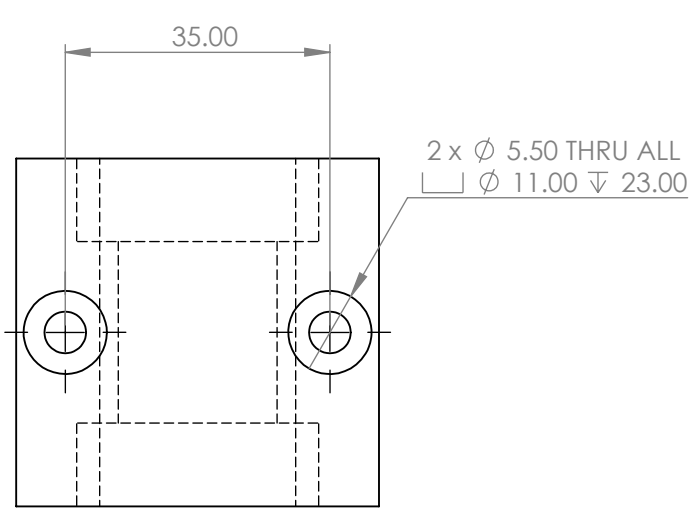
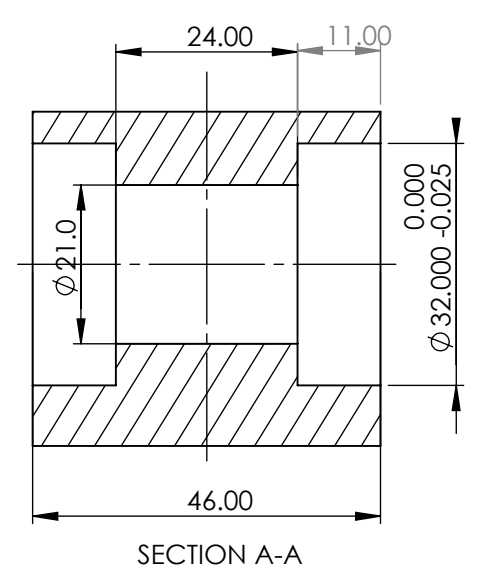
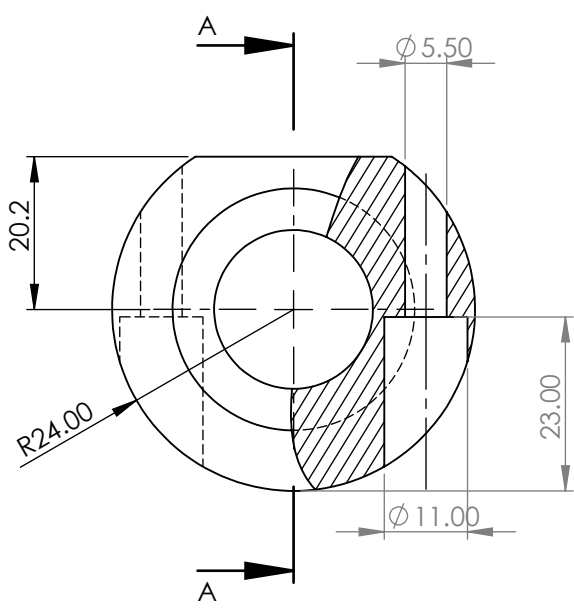

8 Peças p/ Mesa Grande  
4 Peças p/Mesa Pequena

UNLESS OTHERWISE SPECIFIED: DIMENSIONS ARE IN MILLIMETERS SURFACE FINISH: TOLERANCES: LINEAR: ANGULAR:			FINISH:	DEBURR AND BREAK SHARP EDGES	DO NOT SCALE DRAWING	REVISION
					Last saved	10/05/2023
NAME	SIGNATURE	DATE	TITLE: <b>Cubo</b>			
DRAWN Pamies Teixeira						
CHK'D						
APPV'D						
MFG						
Q.A			MATERIAL: 2024-T3	DWG NO. CB-01	A4	
			WEIGHT:	SCALE:1:1	SHEET 1 OF 1	

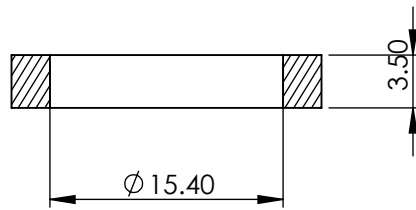
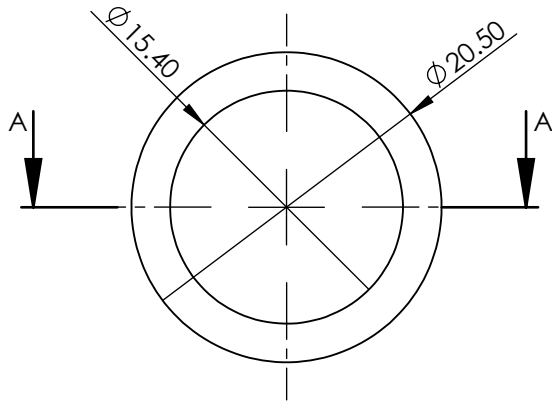

SECTION A-A

UNLESS OTHERWISE SPECIFIED: DIMENSIONS ARE IN MILLIMETERS SURFACE FINISH: TOLERANCES: LINEAR: ANGULAR:				FINISH:		DEBURR AND BREAK SHARP EDGES		DO NOT SCALE DRAWING		REVISION															
								Last saved		09/05/2023															
NAME						SIGNATURE						DATE						TITLE:							
DRAWN																		Espaçador							
CHK'D																									
APPV'D																									
MFG																									
Q.A												MATERIAL:						DWG NO.							
												Material <not specified>						E-01						A4	
												WEIGHT:						SCALE:2:1						SHEET 1 OF 1	



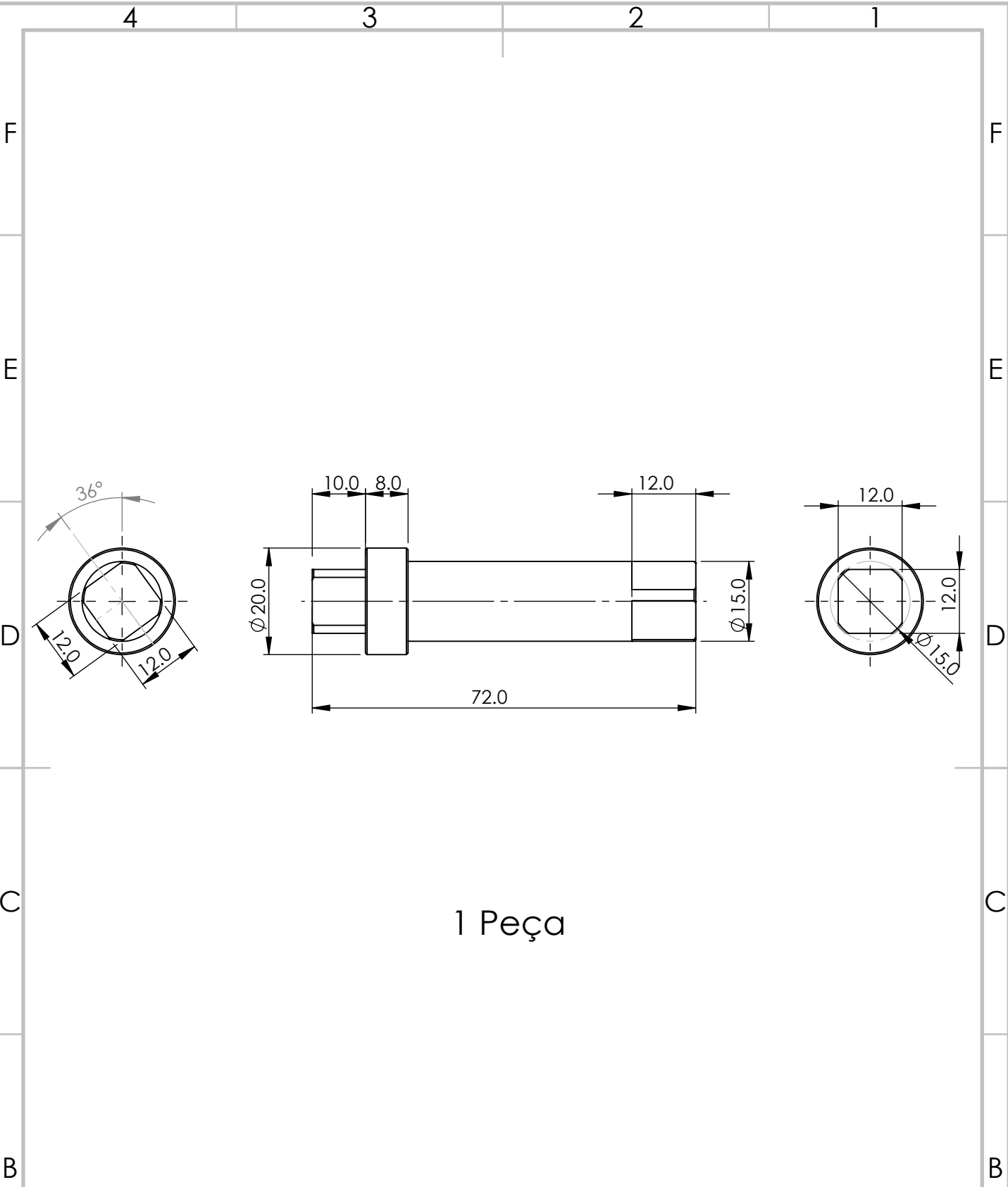

1 Peça

UNLESS OTHERWISE SPECIFIED:  
 DIMENSIONS ARE IN MILLIMETERS  
 SURFACE FINISH:  
 TOLERANCES:  
 LINEAR:  
 ANGULAR:

FINISH:

DEBURR AND  
 BREAK SHARP  
 EDGES

DO NOT SCALE DRAWING

REVISION

Last saved 11/05/2023

	NAME	SIGNATURE	DATE
DRAWN	Pamies Teixeira		
CHK'D			
APPV'D			
MFG			
Q.A			

TITLE:		Veio P Dto	
MATERIAL:		2024 Alloy	
DWG NO.:		V-02	
WEIGHT:		SCALE:1:1	
		SHEET 1 OF 1	

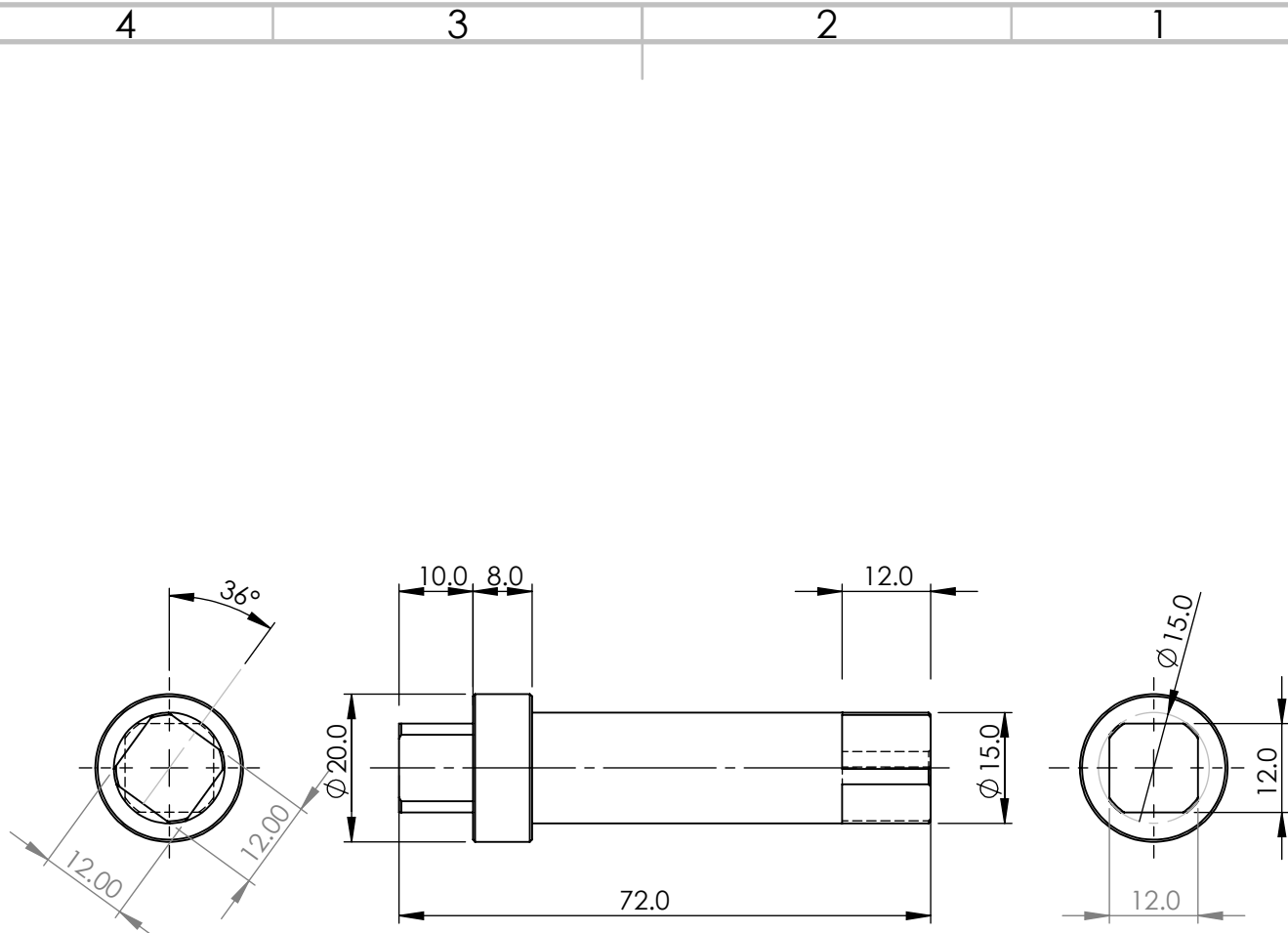

1 Peça

UNLESS OTHERWISE SPECIFIED: DIMENSIONS ARE IN MILLIMETERS SURFACE FINISH: TOLERANCES: LINEAR: ANGULAR:			FINISH:	DEBURR AND BREAK SHARP EDGES	DO NOT SCALE DRAWING	REVISION
					Last saved	11/05/2023
NAME	SIGNATURE	DATE			TITLE: <b>Veio_P Esq</b>	
DRAWN Pamies Teixeira						
CHK'D						
APPV'D						
MFG						
Q.A				MATERIAL: 2024 Alloy	DWG NO. V-02	A4
				WEIGHT:	SCALE:1:1	SHEET 1 OF 1

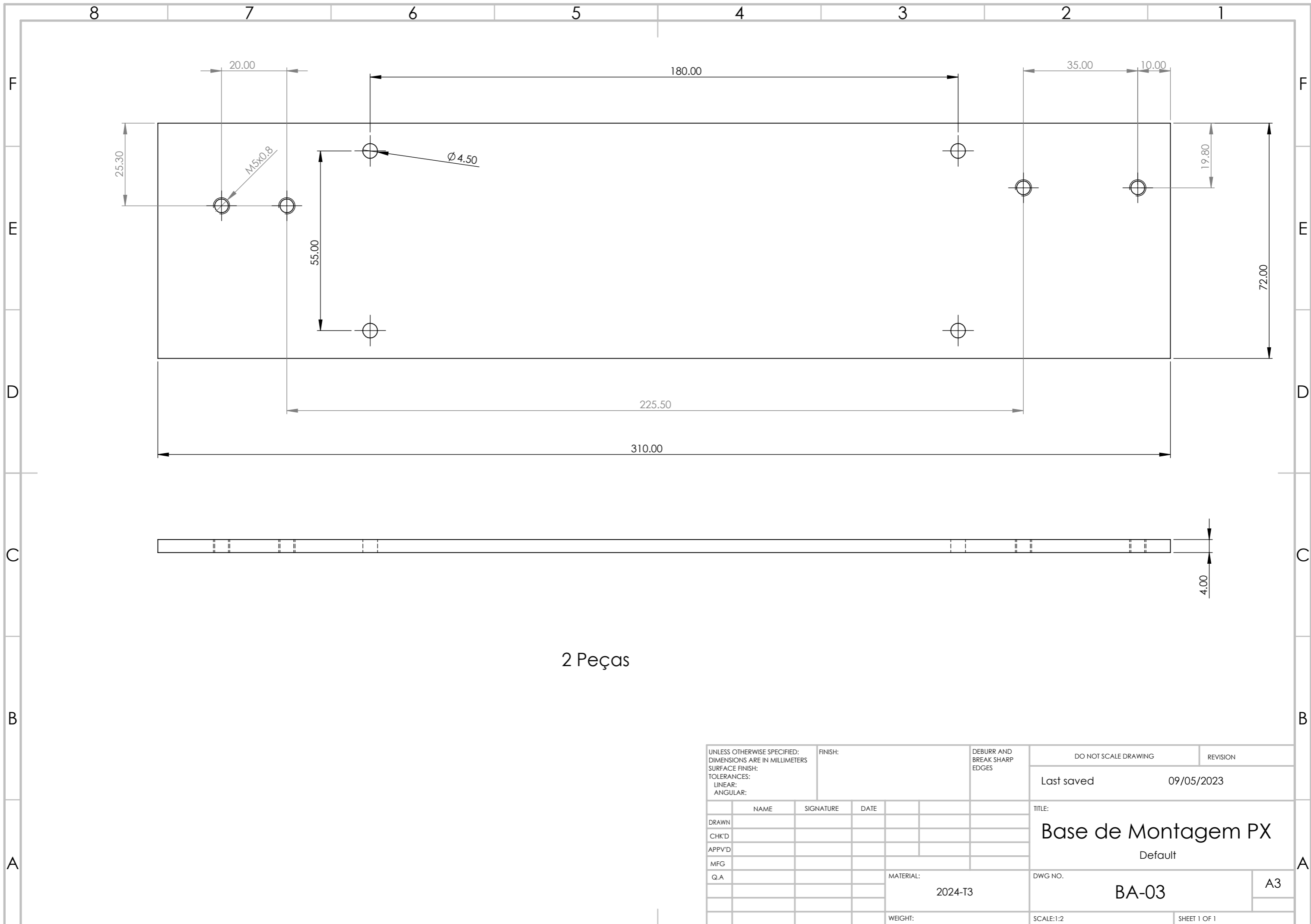

2 Peças

UNLESS OTHERWISE SPECIFIED: DIMENSIONS ARE IN MILLIMETERS SURFACE FINISH: TOLERANCES: LINEAR: ANGULAR:				FINISH:		DEBURR AND BREAK SHARP EDGES		DO NOT SCALE DRAWING		REVISION	
								Last saved		09/05/2023	
DRAWN				NAME		SIGNATURE		DATE		TITLE:	
CHK'D										Base de Montagem PX	
APPV'D										Default	
MFG										DWG NO.	
Q.A								MATERIAL:		A3	
								2024-T3		BA-03	
								WEIGHT:		SCALE:1:2	
										SHEET 1 OF 1	

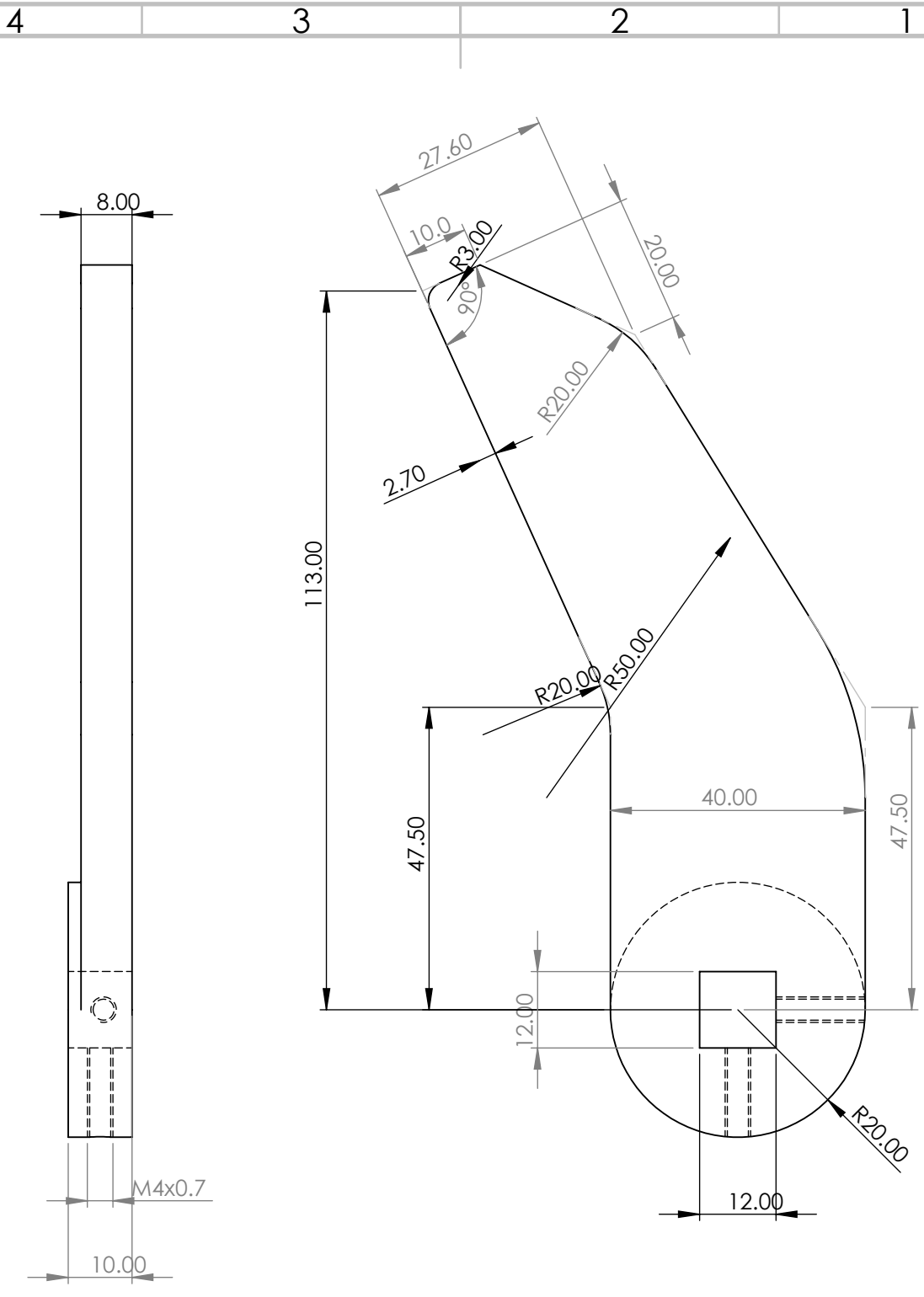

UNLESS OTHERWISE SPECIFIED:  
 DIMENSIONS ARE IN MILLIMETERS  
 SURFACE FINISH:  
 TOLERANCES:  
 LINEAR:  
 ANGULAR:

FINISH:

DEBURR AND  
 BREAK SHARP  
 EDGES

DO NOT SCALE DRAWING

REVISION

Last saved 09/05/2023

	NAME	SIGNATURE	DATE
DRAWN	Pamies Teixeira		
CHK'D			
APPV'D			
MFG			
Q.A			

TITLE:  
**Biela Mandada X**  
 Direita

DWG NO. **BM-03**

MATERIAL:  
 2024-T3

SCALE:1:1

SHEET 1 OF 1

A4

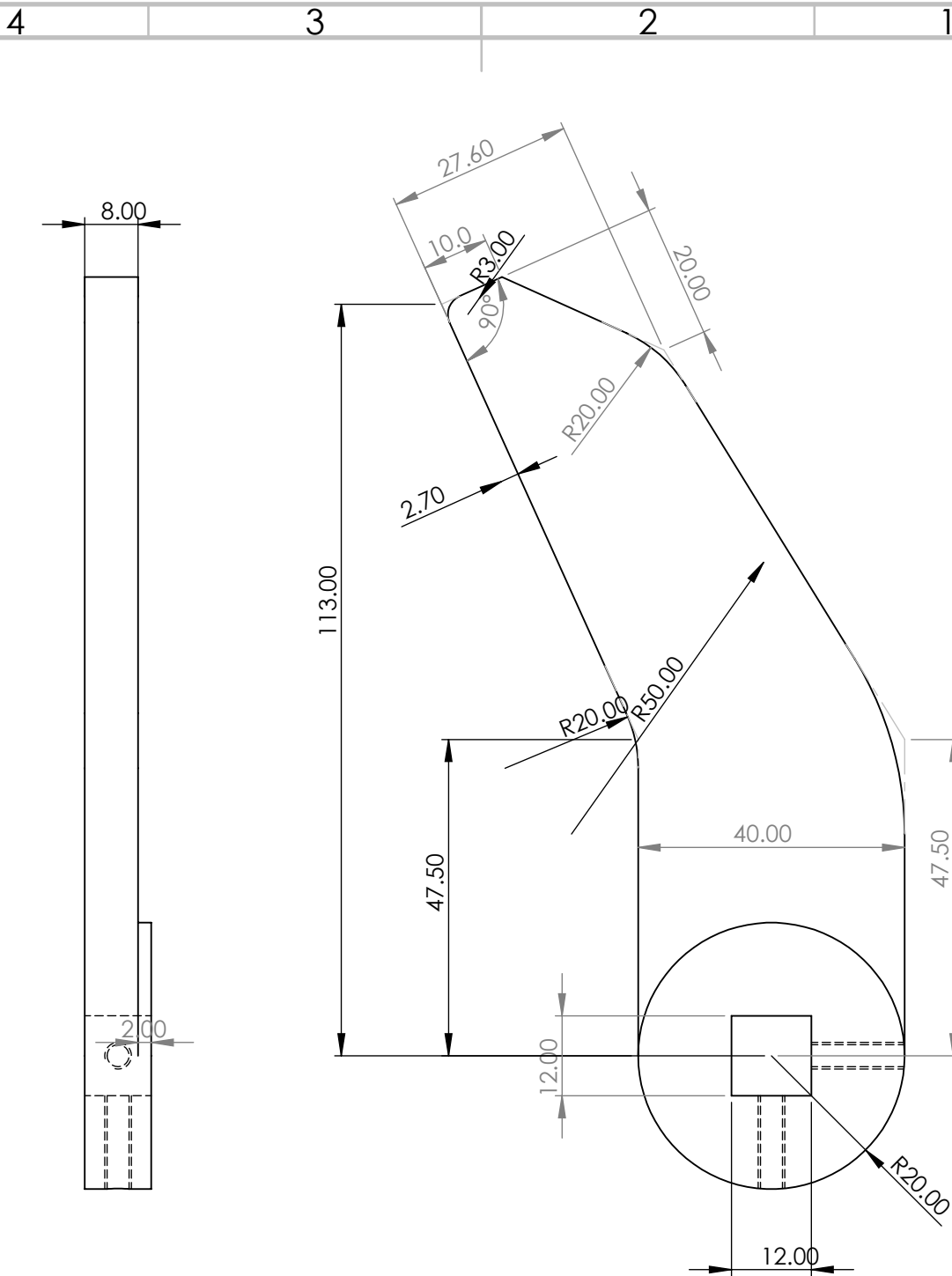

UNLESS OTHERWISE SPECIFIED:  
 DIMENSIONS ARE IN MILLIMETERS  
 SURFACE FINISH:  
 TOLERANCES:  
 LINEAR:  
 ANGULAR:

FINISH:

DEBURR AND  
 BREAK SHARP  
 EDGES

DO NOT SCALE DRAWING

REVISION

Last saved

09/05/2023

	NAME	SIGNATURE	DATE
DRAWN	Pamies Teixeira		
CHK'D			
APPV'D			
MFG			
Q.A			

TITLE:	
Biela Mandada X Esquerda	
MATERIAL:	DWG NO.
Material <not specified>	BM-03
WEIGHT:	SCALE:1:1
	SHEET 1 OF 1

A4

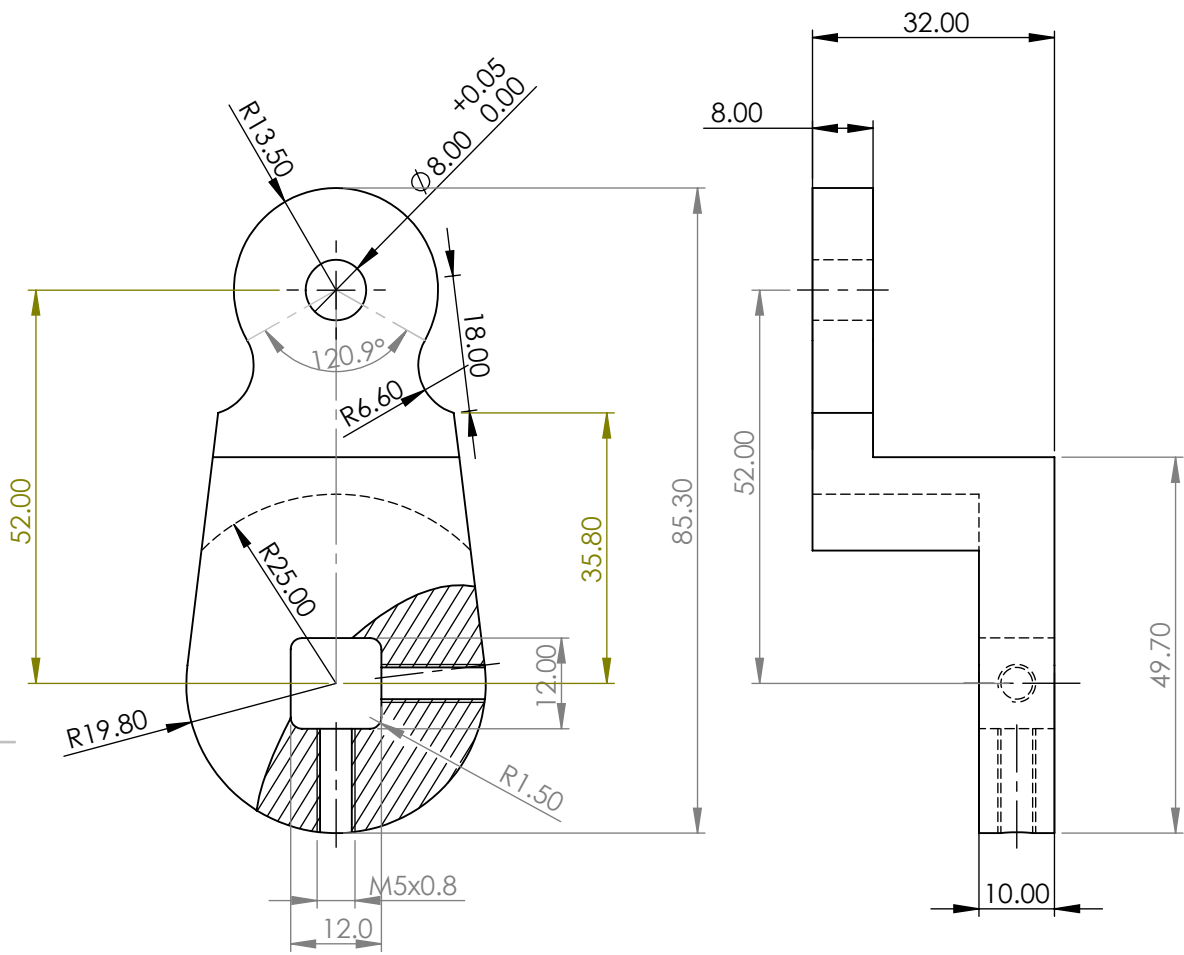

8 Peças p/ Mesa Grande  
4 Peças p/ Mesa Pequena

UNLESS OTHERWISE SPECIFIED:  
DIMENSIONS ARE IN MILLIMETERS  
SURFACE FINISH:  
TOLERANCES:  
LINEAR:  
ANGULAR:

FINISH:

DEBURR AND  
BREAK SHARP  
EDGES

DO NOT SCALE DRAWING

REVISION

Last saved

11/05/2023

	NAME	SIGNATURE	DATE
DRAWN	Pamies Teixeira		
CHK'D			
APPV'D			
MFG			
Q.A			

TITLE:		Biela Mandante	
MATERIAL:		2024-T3	
DWG NO.:		BD-01	
WEIGHT:		SCALE:1:1	
		SHEET 1 OF 1	

A4

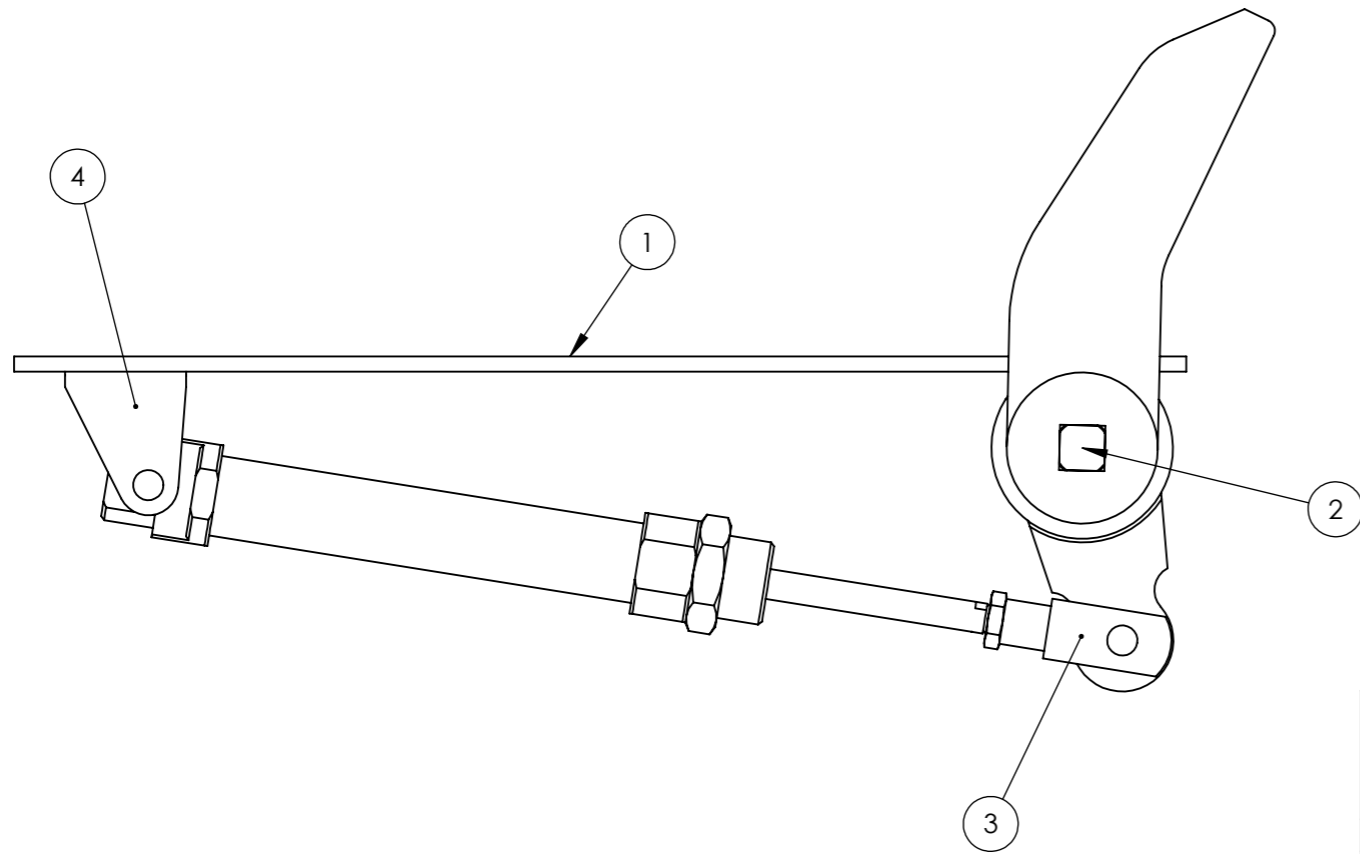
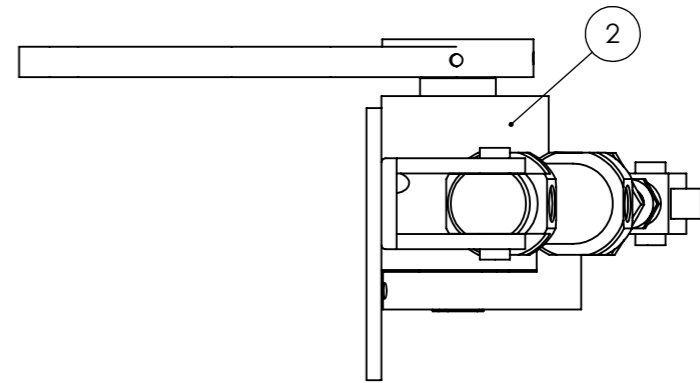
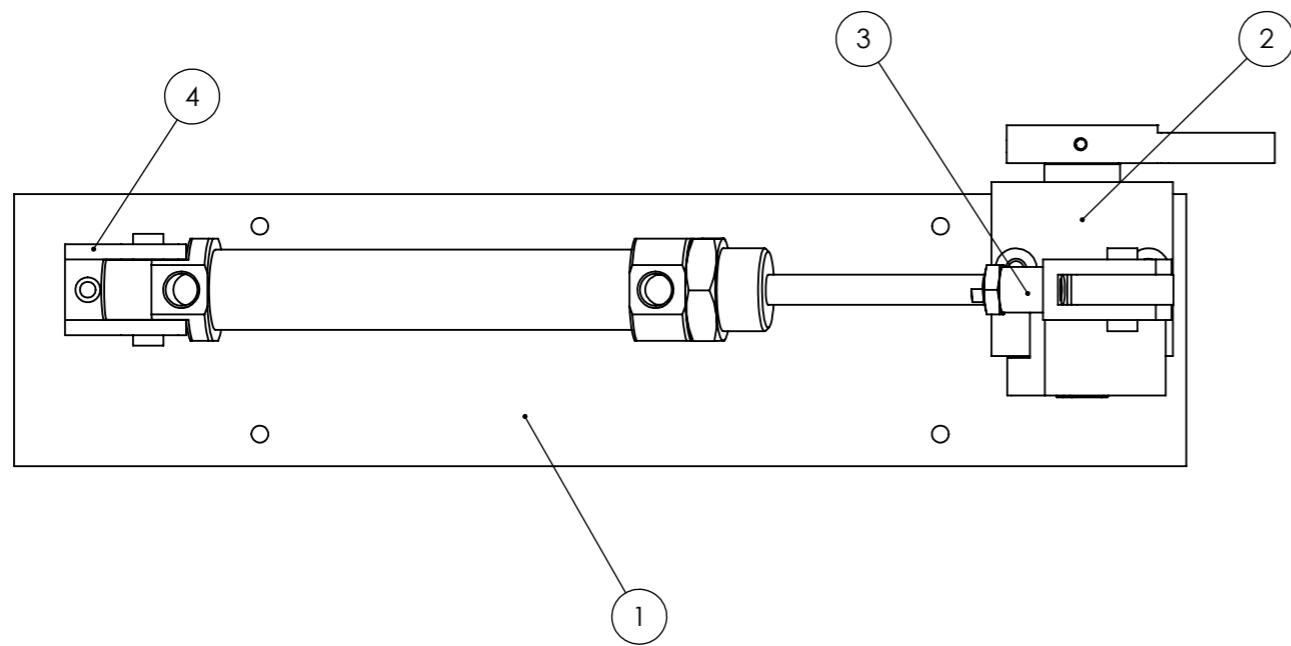

1 Conjunto

ITEM NO.	PART NUMBER	QTY.
1	Base_Montagem_PX	1
2	CorpoPusher_Dto_X	1
3	RM_8020_M_75+QM_8020_38+M_P19409+M_P13615(Magnetic Piston,0,B,0,)	1
4	QM_8020_44_20_CA	1

UNLESS OTHERWISE SPECIFIED: DIMENSIONS ARE IN MILLIMETERS SURFACE FINISH: TOLERANCES: LINEAR: ANGULAR:			FINISH:		DEBURR AND BREAK SHARP EDGES		DO NOT SCALE DRAWING		REVISION		
							Last saved		11/05/2023		
							TITLE: <b>Conjunto Dto PX</b> Default				
							DWG NO. <b>PD-003</b>			A3	
							SCALE:1:5		SHEET 1 OF 1		

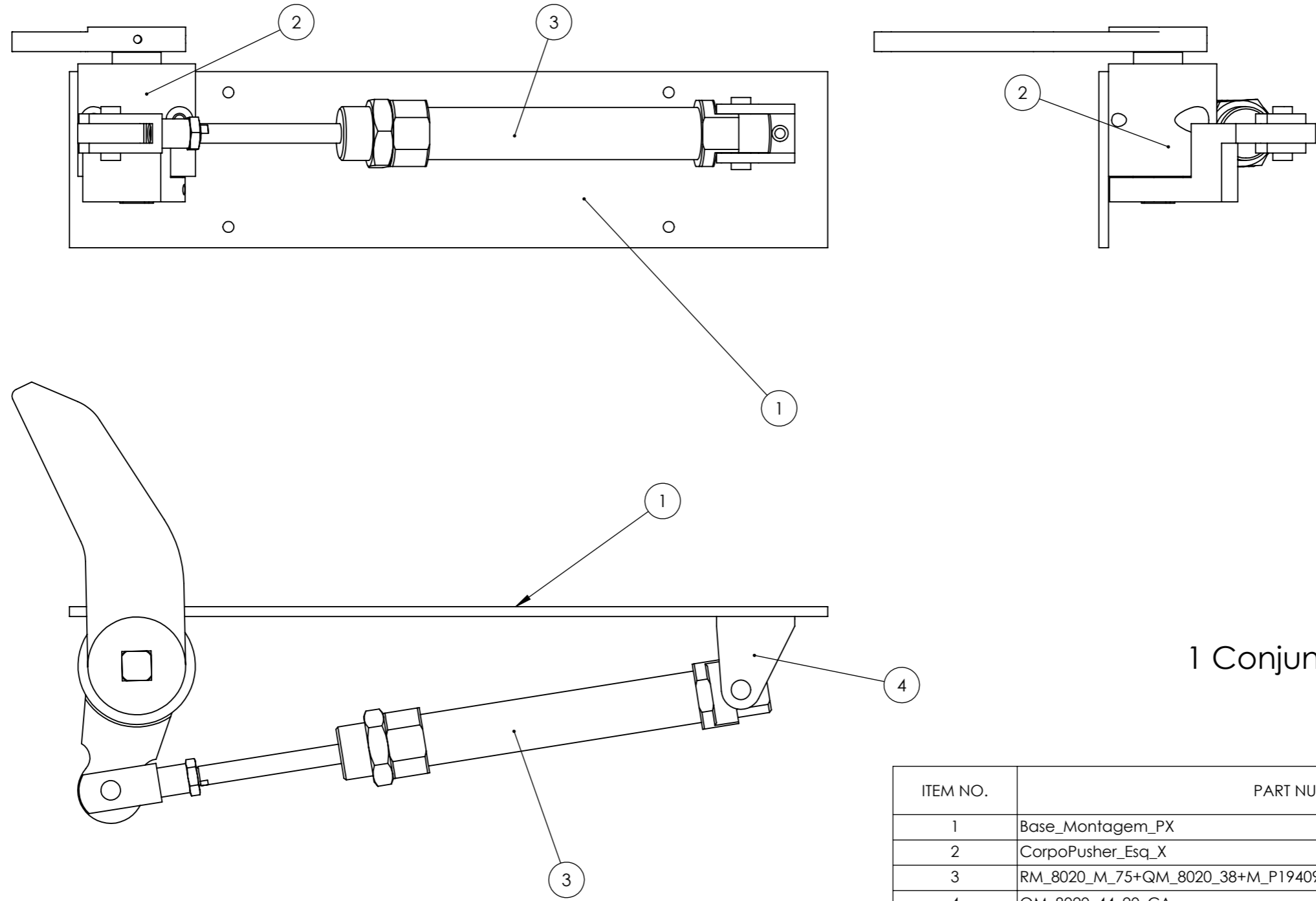

1 Conjunto

ITEM NO.	PART NUMBER	QTY.
1	Base_Montagem_PX	1
2	CorpoPusher_Esq_X	1
3	RM_8020_M_75+QM_8020_38+M_P19409+M_P13615(Magnetic Piston,0,B,0,)	1
4	QM_8020_44_20_CA	1

UNLESS OTHERWISE SPECIFIED: DIMENSIONS ARE IN MILLIMETERS SURFACE FINISH: TOLERANCES: LINEAR: ANGULAR:			FINISH:		DEBURR AND BREAK SHARP EDGES		DO NOT SCALE DRAWING		REVISION		
							Last saved		11/05/2023		
							TITLE: <b>Conjunto Esq PX</b> Default				
DRAWN Pamies Teixeira			SIGNATURE		DATE		DWG NO.		PD-004		A3
CHK'D							MATERIAL:		SCALE:1:5		SHEET 1 OF 1
APPV'D							WEIGHT:				
MFG											
Q.A											



4 3 2 1

F

F

E

E

D

D

C

C

B

B

A

A

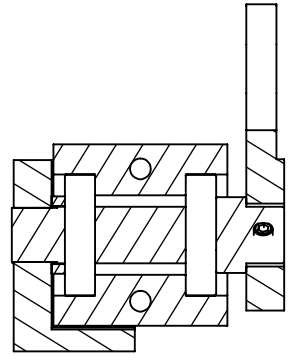
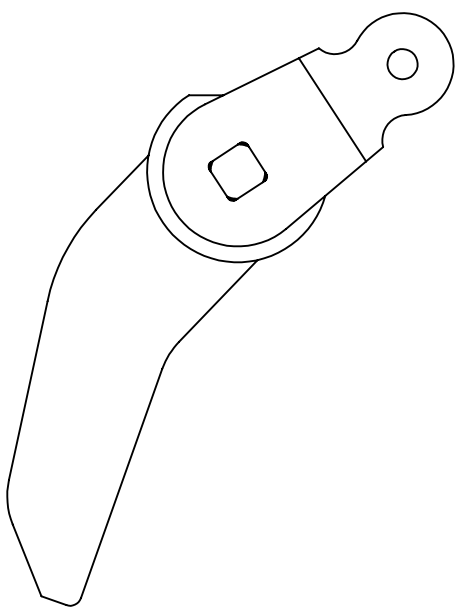
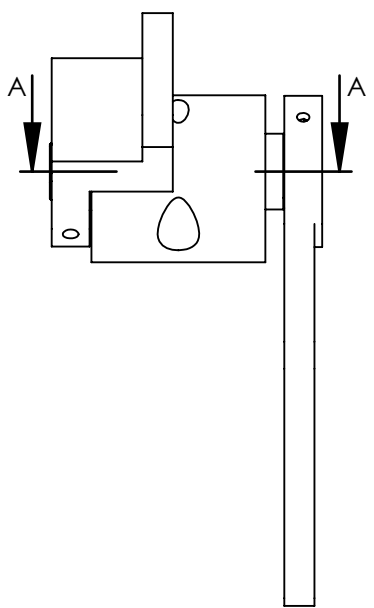

SECTION A-A

ITEM NO.	PART NUMBER	QTY.
1	Cubo_V3	1
2	Veio_PX-Dto	1
3	BielaMandada_Peq_X	1
4	BielaMandante	1
5	Espaçador	1
6	SKF - 16002 - 12,SI,NC,12_68	2

UNLESS OTHERWISE SPECIFIED:  
 DIMENSIONS ARE IN MILLIMETERS  
 SURFACE FINISH:  
 TOLERANCES:  
 LINEAR:  
 ANGULAR:

FINISH:

DEBURR AND  
 BREAK SHARP  
 EDGES

DO NOT SCALE DRAWING      REVISION  
 Last saved      11/05/2023

	NAME	SIGNATURE	DATE
DRAWN			
CHK'D			
APPV'D			
MFG			
Q.A			

TITLE:  
**Corpo Pusher Dto**

MATERIAL:  
 DWG NO.      A4

WEIGHT:  
 SCALE:1:2      SHEET 1 OF 1

4 3 2 1

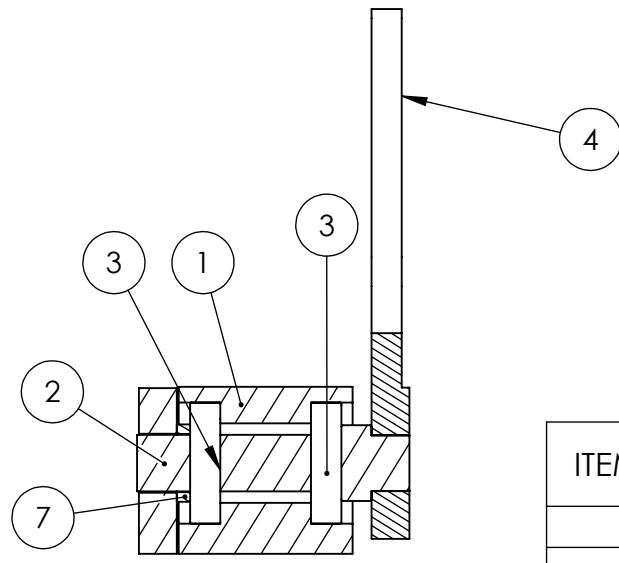
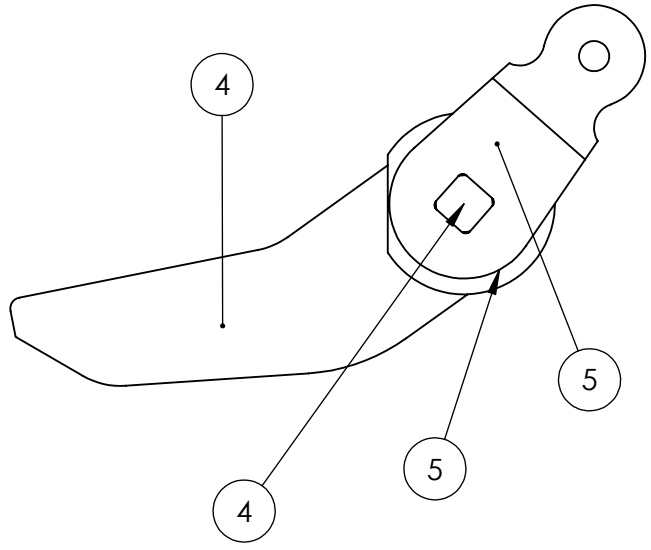
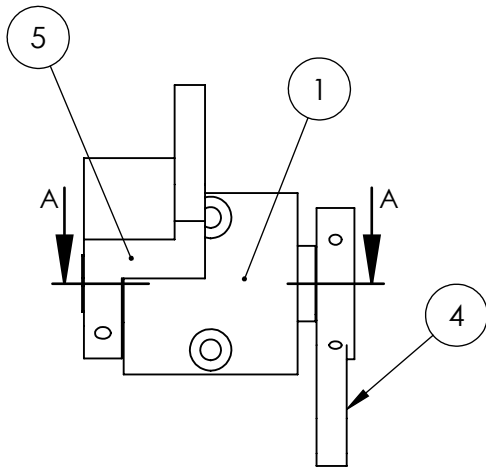

1 Conjunto

ITEM NO.	PART NUMBER	QTY.
1	Cubo_V3	1
2	Veio_PX-Esq	1
3	SKF - 16002 - 12,SI,NC,12_68	2
4	BielaMandada_Peq_X	1
5	BielaMandante	1
6	ISO 4028 - M5 x 10-N	1
7	Espaçador	1

UNLESS OTHERWISE SPECIFIED:  
 DIMENSIONS ARE IN MILLIMETERS  
 SURFACE FINISH:  
 TOLERANCES:  
 LINEAR:  
 ANGULAR:

FINISH:  
  
 DEBURR AND  
 BREAK SHARP  
 EDGES

DO NOT SCALE DRAWING  
 REVISION  
 Last saved  
 11/05/2023

	NAME	SIGNATURE	DATE
DRAWN			
CHK'D			
APPV'D			
MFG			
Q.A			

TITLE:  
**Corpo Pusher Esquerdo**  
  
 DWG NO. A4  
 SCALE:1:2  
 SHEET 1 OF 1

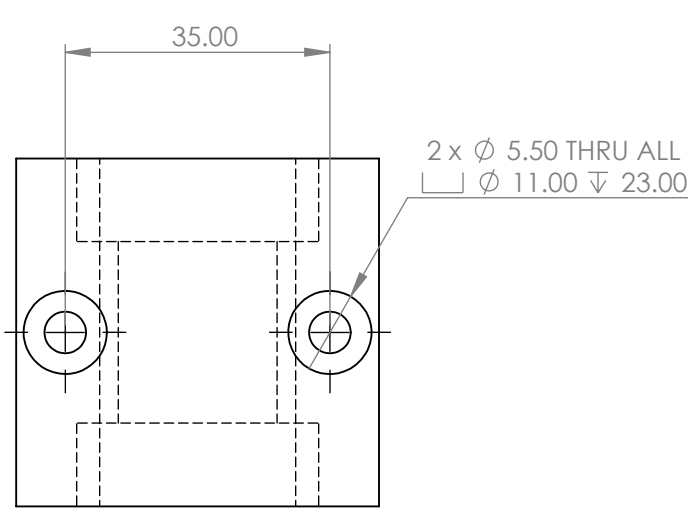
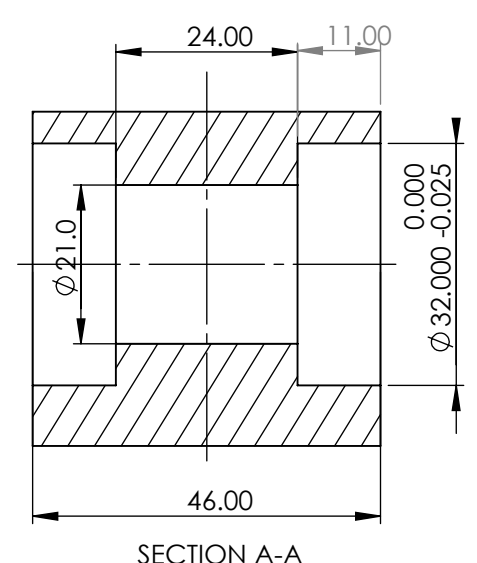
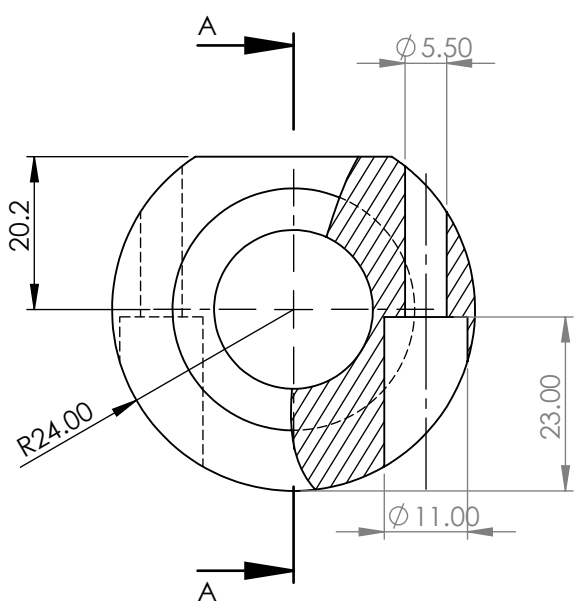

8 Peças p/ Mesa Grande  
4 Peças p/Mesa Pequena

UNLESS OTHERWISE SPECIFIED: DIMENSIONS ARE IN MILLIMETERS SURFACE FINISH: TOLERANCES: LINEAR: ANGULAR:			FINISH:	DEBURR AND BREAK SHARP EDGES	DO NOT SCALE DRAWING	REVISION
					Last saved	10/05/2023
NAME	SIGNATURE	DATE	TITLE: <b>Cubo</b>			
DRAWN Pamies Teixeira						
CHK'D						
APPV'D						
MFG						
Q.A			MATERIAL: 2024-T3	DWG NO. CB-01	A4	
			WEIGHT:	SCALE:1:1	SHEET 1 OF 1	

4 3 2 1

F

F

E

E

D

D

C

C

B

B

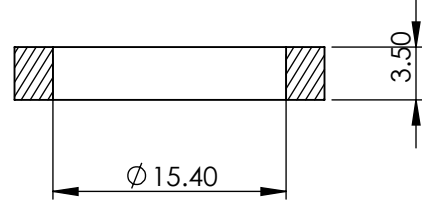
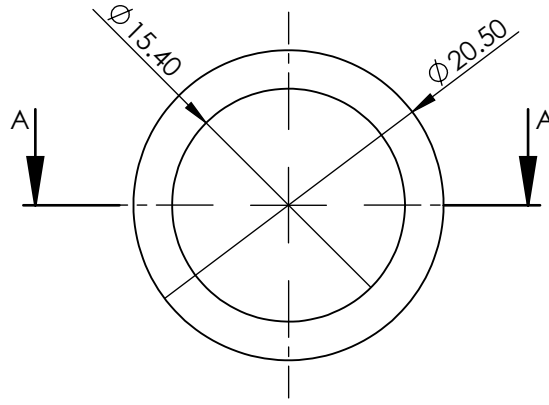

SECTION A-A

UNLESS OTHERWISE SPECIFIED:  
 DIMENSIONS ARE IN MILLIMETERS  
 SURFACE FINISH:  
 TOLERANCES:  
 LINEAR:  
 ANGULAR:

FINISH:

DEBURR AND  
 BREAK SHARP  
 EDGES

DO NOT SCALE DRAWING

REVISION

Last saved 09/05/2023

	NAME	SIGNATURE	DATE
DRAWN			
CHK'D			
APPV'D			
MFG			
Q.A			

TITLE:  
**Espaçador**

MATERIAL:  
 Material <not specified>

DWG NO.  
**E-01**

SCALE:2:1

SHEET 1 OF 1

A

A

4 3 2 1

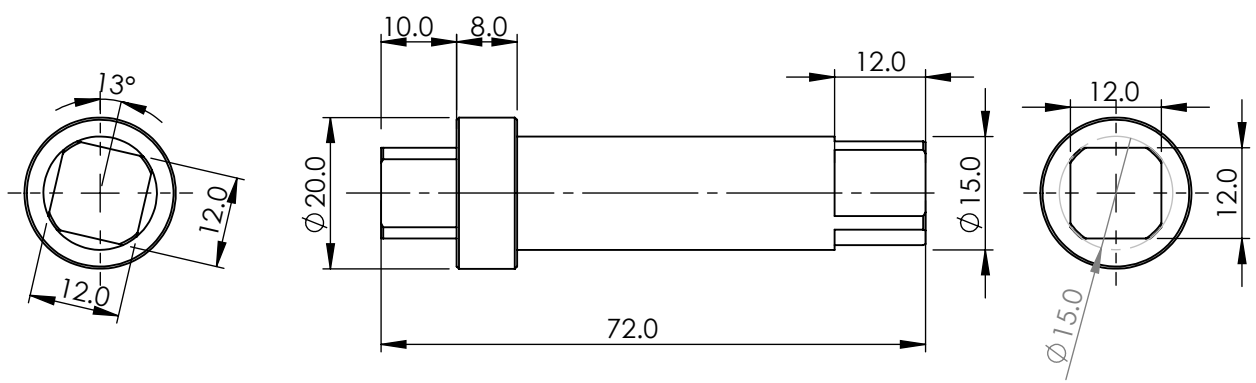

1 Peça

UNLESS OTHERWISE SPECIFIED: DIMENSIONS ARE IN MILLIMETERS SURFACE FINISH: TOLERANCES: LINEAR: ANGULAR:			FINISH:		DEBURR AND BREAK SHARP EDGES		DO NOT SCALE DRAWING		REVISION	
							Last saved		11/05/2023	
NAME			SIGNATURE		DATE		TITLE:			
DRAWN Pamies Teixeira							Veio PX Dto			
CHK'D										
APPV'D										
MFG										
Q.A					MATERIAL:		DWG NO.		A4	
					2024-T3		V-03			
					WEIGHT:		SCALE:1:1		SHEET 1 OF 1	

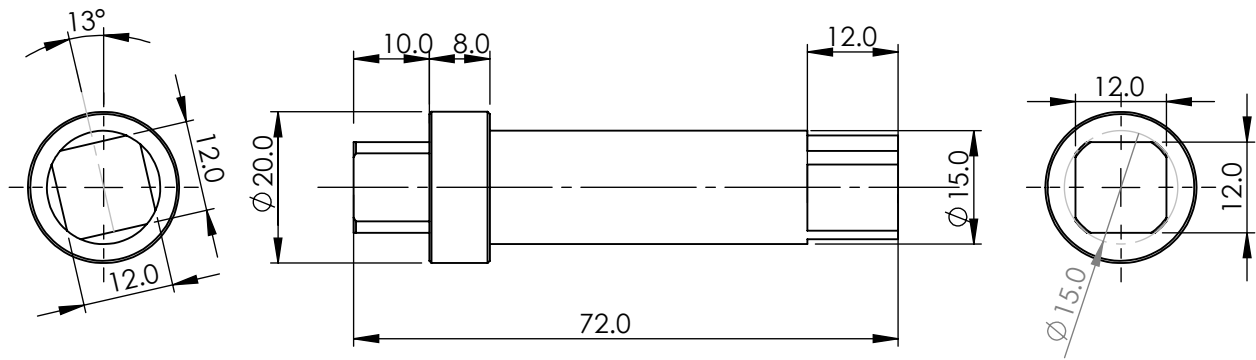

UNLESS OTHERWISE SPECIFIED:  
 DIMENSIONS ARE IN MILLIMETERS  
 SURFACE FINISH:  
 TOLERANCES:  
 LINEAR:  
 ANGULAR:

FINISH:

DEBURR AND  
 BREAK SHARP  
 EDGES

DO NOT SCALE DRAWING  
 Last saved

REVISION  
 11/05/2023

	NAME	SIGNATURE	DATE
DRAWN	Pamies Teixeira		
CHK'D			
APPV'D			
MFG			
Q.A			

TITLE:  
**Veio PX Esq**

DWG NO.  
**V-04**

SCALE:1:1

SHEET 1 OF 1

MATERIAL:  
 2024-T3

WEIGHT:

A4