

PART NUMBER	DESCRIPTION	QTY.	ITEM NO.
Perfil_20x20	Perfil Bosch L=283	7	1
Perfil_20x20	Perfil Bosch L=483	2	2
842 523 508	Corner_Bracket 20x20	6	3
Corner_Bracket_20x20		12	4
ESA01.P.005-JOINT		4	5
ESA01.P.003-JOINT		2	6
ESA01.P.006-JOINT		4	7
ESA01.P.004-JOINT		3	8
ESA01.P.001-Haste		3	9
ESA01.P.001-Haste		1	10
ESA01.P.002-BUSHING		4	11
SD 4762 M8 x 35 - 35N		4	12
Washer ISO 7089 - 8		16	13
KF - 608 - 8,SI,NC,8_68		4	14
Barra_Tracção		1	15
Fixo		2	16
Perfil_20x20	Perfil Bosch L=323	2	17
ESA01.P.004-JOINT		2	18
ESA01.P.003-JOINT		2	19
ESA01.P.002-BUSHING		9	20
SD 10512-M8x1.0-N		8	21
stepper_am23hs3454-01_01		1	22
Part2*Nema23-Reducer_v2		1	23
Part3*Nema23-Reducer_v2		1	24
AX_Rolam		1	25
KF - 6001 - 10,SI,NC,10_68		1	26
KF - 51201 - 8,SI,NC,8_68		1	27
3012_1030		1	28
uso_Roscado		1	29
ruarc 5100-46 - S0.469		1	30
Perfil_20x20		1	31
Placa de fixação		1	32
Porca_Casquilho		1	33
SD 4762 M4 x 10 - 10N		6	34
SD 4762 M8 x 40 - 28N		2	35
SD 4762 M8 x 25 - 25N		2	36
_NUT_N6		4	37
SD 4762 M4 x 8 - 8N		1	38
SD 10673-4.55-S		1	39
SD 10642-M4 x 8 - 8N		1	40

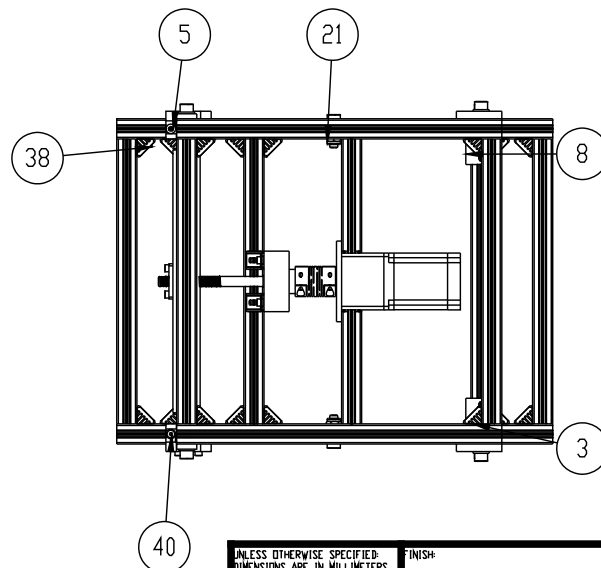

UNLESS OTHERWISE SPECIFIED: DIMENSIONS ARE IN MILLIMETERS		FINISH:		DEBURR AND BREAK SHARP EDGES		DO NOT SCALE DRAWING		REVISION	
SURFACE FINISH:									
TOLERANCES:									
LINEAR:									
ANGULAR:									
NAME	SIGNATURE	DATE				TITLE:			
DRAWN									
CHK'D									
APP'VD									
MFG									
D.A.						MATERIAL:		DWG. NO. MESA01.A.000-V2 A3	
						WEIGHT:		SCALE:	
								SHEET 1 OF 14	

SOLIM  
For instructional use only.

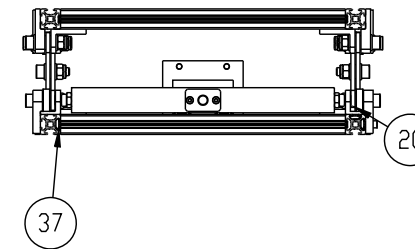
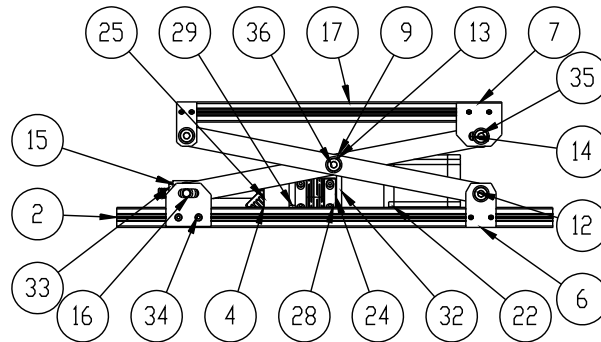
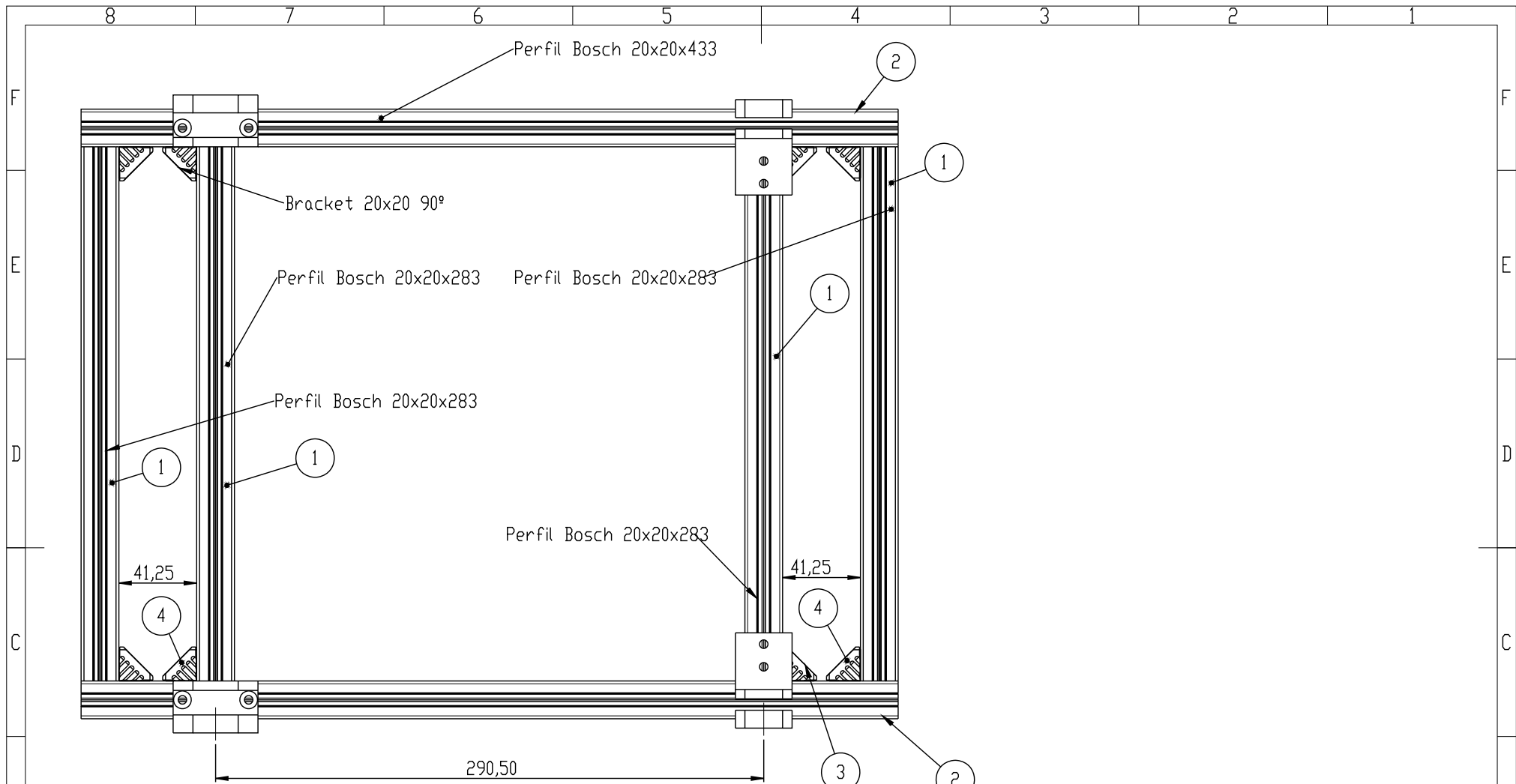

ITEM NO.	PART NUMBER	DESCRIPTION	QTY.
1	Perfil_20x20	Perfil Bosch L=283	4
2	Perfil_20x20	Perfil Bosch L=433	2
3	3 842 523 508	Corner_Bracket 20x20	1
4	Corner_Bracket_20x20		7
5	MESA01.P.005-JOINT		2
6	MESA01.P.003-JOINT		2
7	MESA01.P.006-JOINT		2
8	MESA01.P.004-JOINT		2

UNLESS OTHERWISE SPECIFIED: DIMENSIONS ARE IN MILLIMETERS				FINISH:		DEBURR AND BREAK SHARP EDGES		DO NOT SCALE DRAWING		REVISION	
SURFACE FINISH:				TOLERANCES:		LINEAR:		ANGULAR:		TITLE:	
DRAWN	NAME	SIGNATURE	DATE							DWG NO.	
CHK'D										Estrutura Superior A3	
APPV'D										SCALE:1:5	
MFG										SHEET 2 OF 14	
D.A										WEIGHT:	

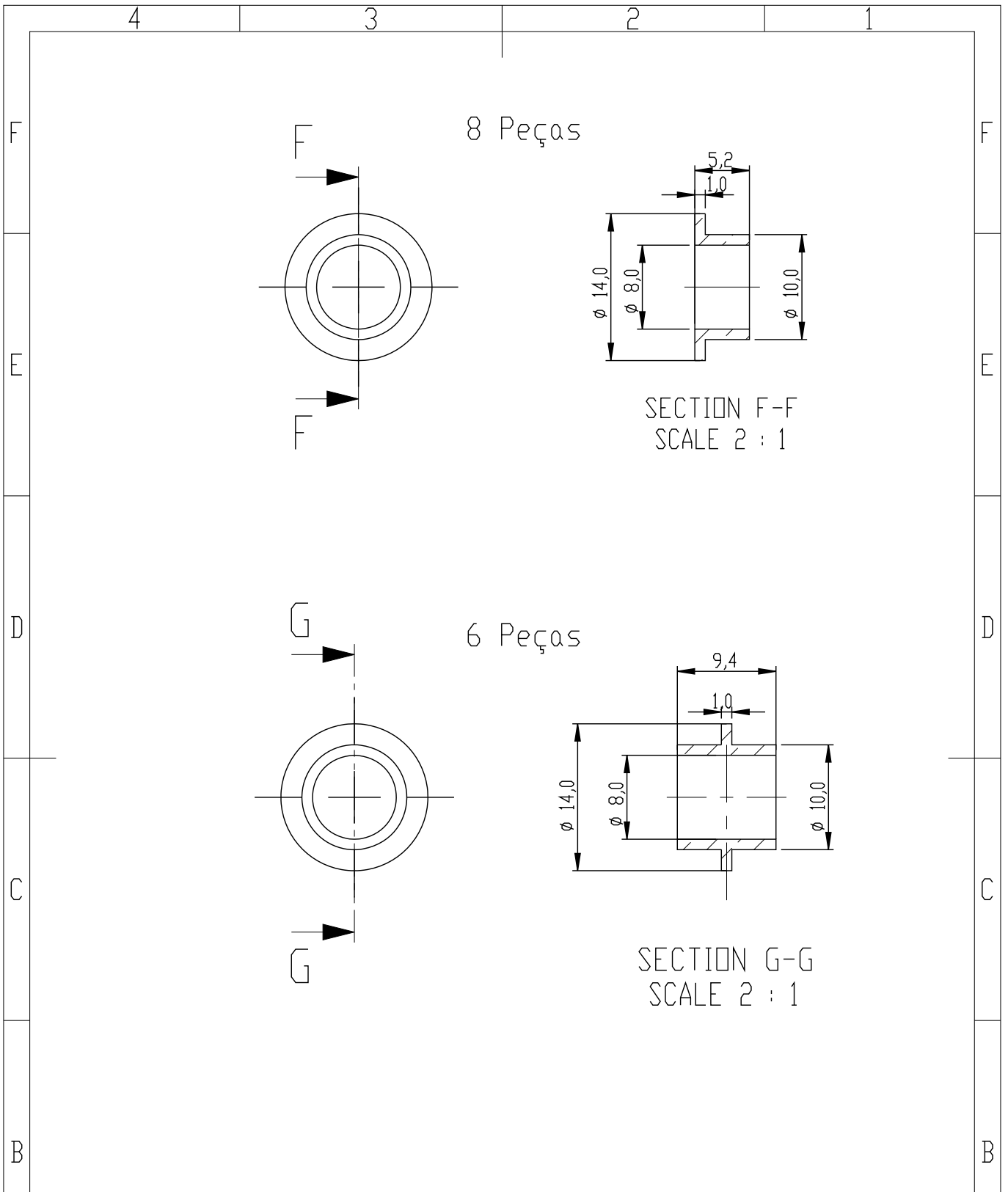

UNLESS OTHERWISE SPECIFIED: DIMENSIONS ARE IN MILLIMETERS SURFACE FINISH: TOLERANCES: LINEAR: ANGULAR:	FINISH:			DEBURR AND BREAK SHARP EDGES	DO NOT SCALE DRAWING	REVISION

	NAME	SIGNATURE	DATE		TITLE:
DRAWN					
CHK'D					
APPV'D					
MFG					

Q.A				MATERIAL: Bronze Fosforoso	DWG NO. Casquilhos	A4
				WEIGHT:	SCALE:1:1	SHEET 13 OF 14

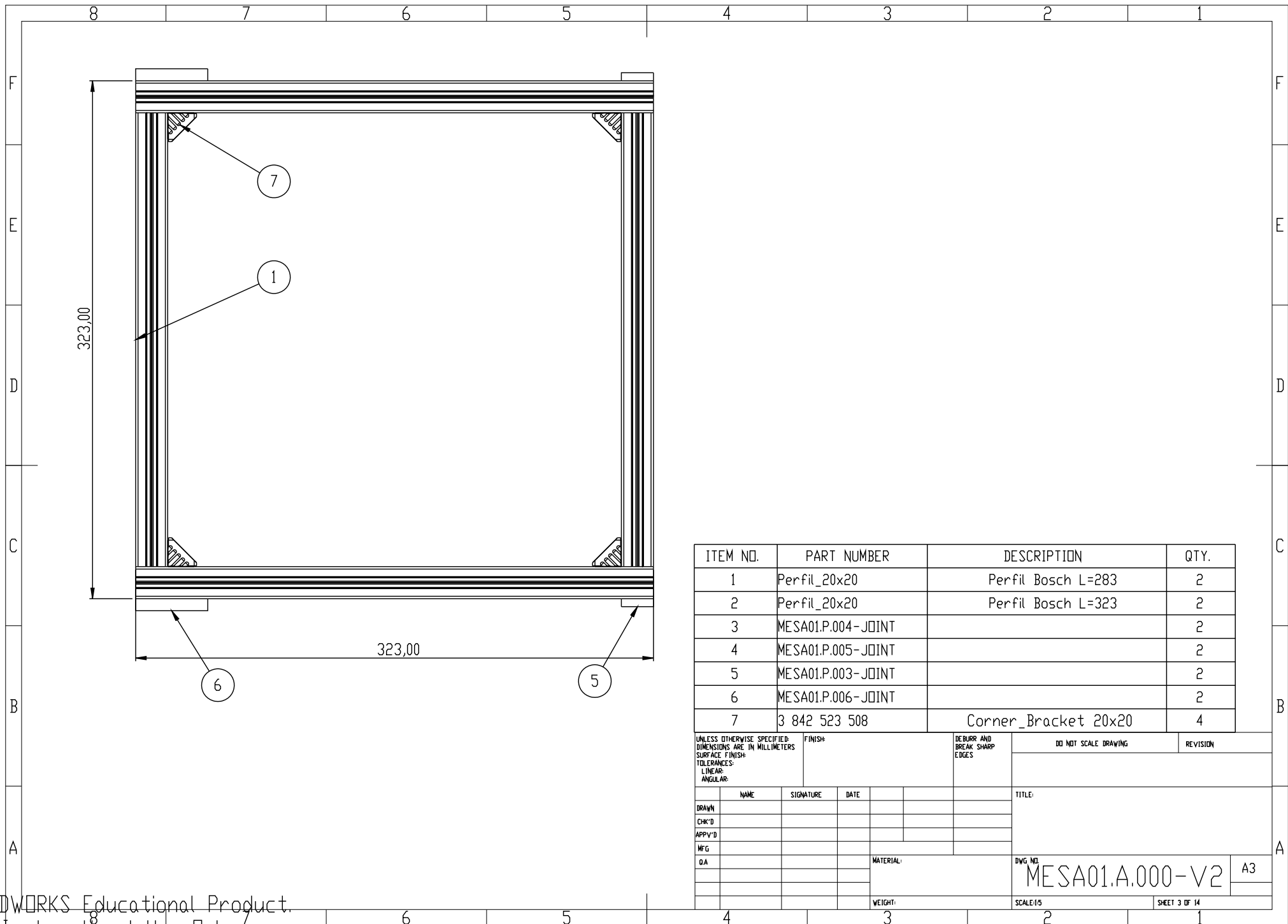

ITEM NO.	PART NUMBER	DESCRIPTION	QTY.
1	Perfil_20x20	Perfil Bosch L=283	2
2	Perfil_20x20	Perfil Bosch L=323	2
3	MESA01.P.004-JOINT		2
4	MESA01.P.005-JOINT		2
5	MESA01.P.003-JOINT		2
6	MESA01.P.006-JOINT		2
7	3 842 523 508	Corner_Bracket 20x20	4

UNLESS OTHERWISE SPECIFIED: DIMENSIONS ARE IN MILLIMETERS				FINISH:		DEBURR AND BREAK SHARP EDGES		DO NOT SCALE DRAWING		REVISION	
SURFACE FINISH:											
TOLERANCES:											
LINEAR:											
ANGULAR:											
DRAWN		SIGNATURE		DATE		TITLE:					
CHK'D											
APP'V'D											
MFG											
D.A						MATERIAL:		DWG. NO.		A3	
								MESA01.A.000-V2			
						WEIGHT:		SCALE:1:5		SHEET 3 OF 14	

SOLIDWORKS Educational Product.  
For Instructional Use Only.

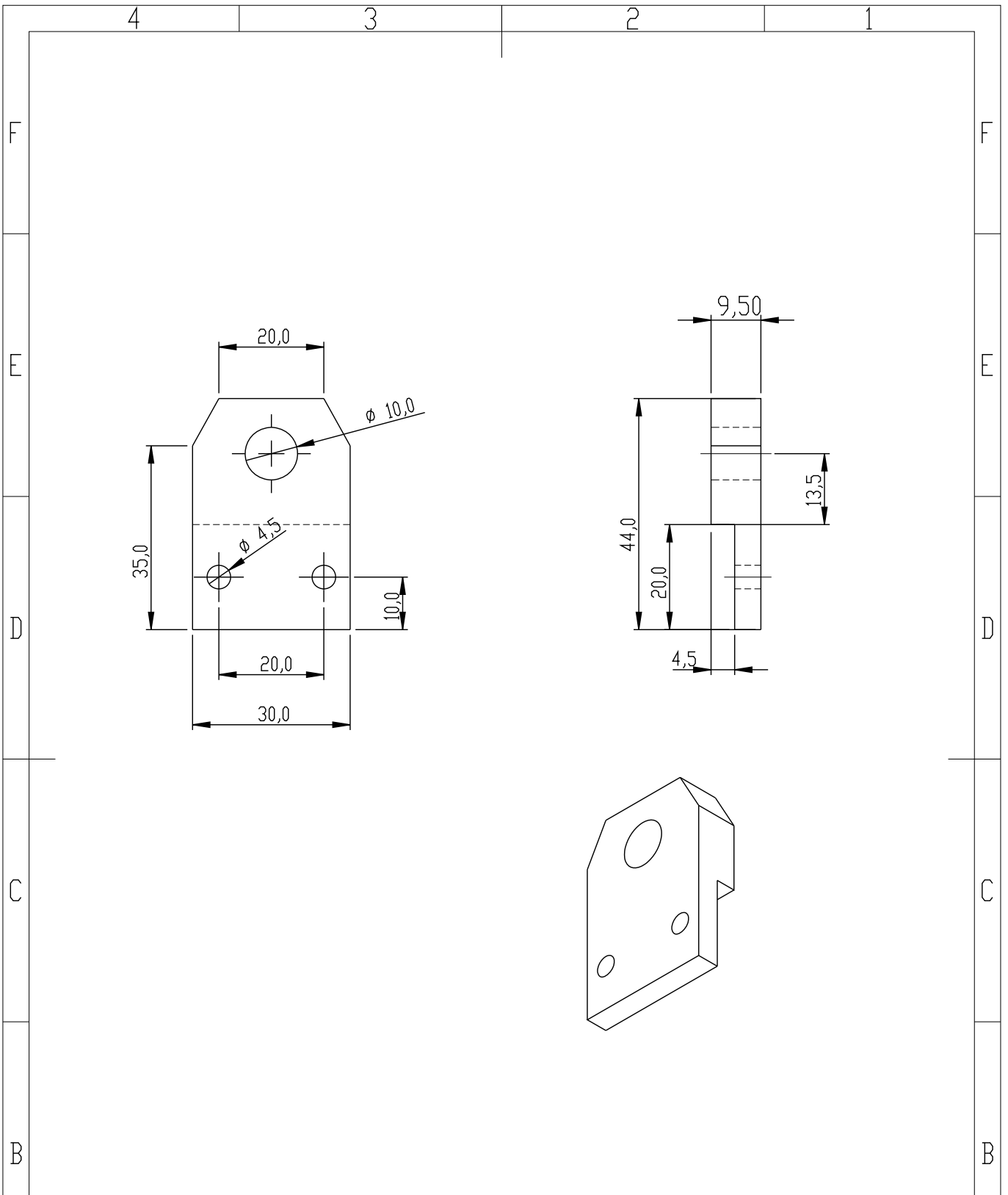

UNLESS OTHERWISE SPECIFIED: DIMENSIONS ARE IN MILLIMETERS SURFACE FINISH: TOLERANCES: LINEAR: ANGULAR:	FINISH:	DEBURR AND BREAK SHARP EDGES	DO NOT SCALE DRAWING	REVISION
---	---------	------------------------------------	----------------------	----------

A		NAME	SIGNATURE	DATE		TITLE:
	DRAWN					
	CHK'D					
	APPV'D					
	MFG					
	Q.A					
		MATERIAL: <b>AL7075-T651</b>			DWG. NO. <b>MESA01.P.003-Joint</b>	<b>A4</b>
		WEIGHT:	SCALE:1:1		SHEET 4 OF 14	

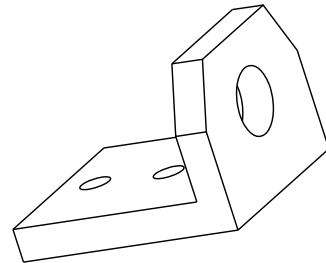
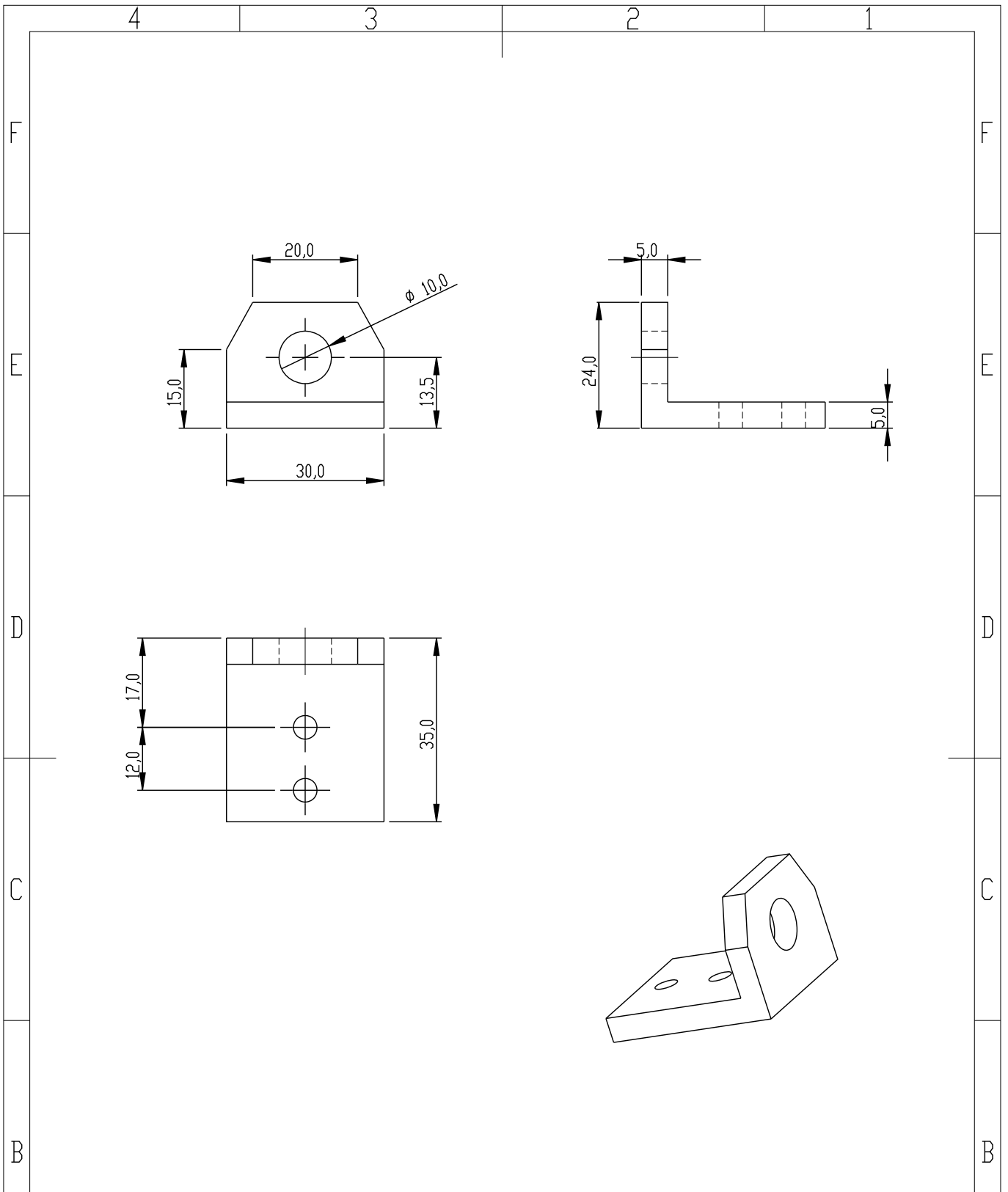

UNLESS OTHERWISE SPECIFIED: DIMENSIONS ARE IN MILLIMETERS SURFACE FINISH: TOLERANCES: LINEAR: ANGULAR:	FINISH:			DEBURR AND BREAK SHARP EDGES	DO NOT SCALE DRAWING	REVISION

A	NAME	SIGNATURE	DATE	MATERIAL: <b>AL7075-T651</b>	TITLE: <b>MESA01.P.004-Joint</b>	DWG NO. <b>A4</b>
	DRAWN					
	CHK'D					
	APPV'D					
	MFG					
	Q.A					
			WEIGHT:	SCALE:1:1	SHEET 5 OF 14	

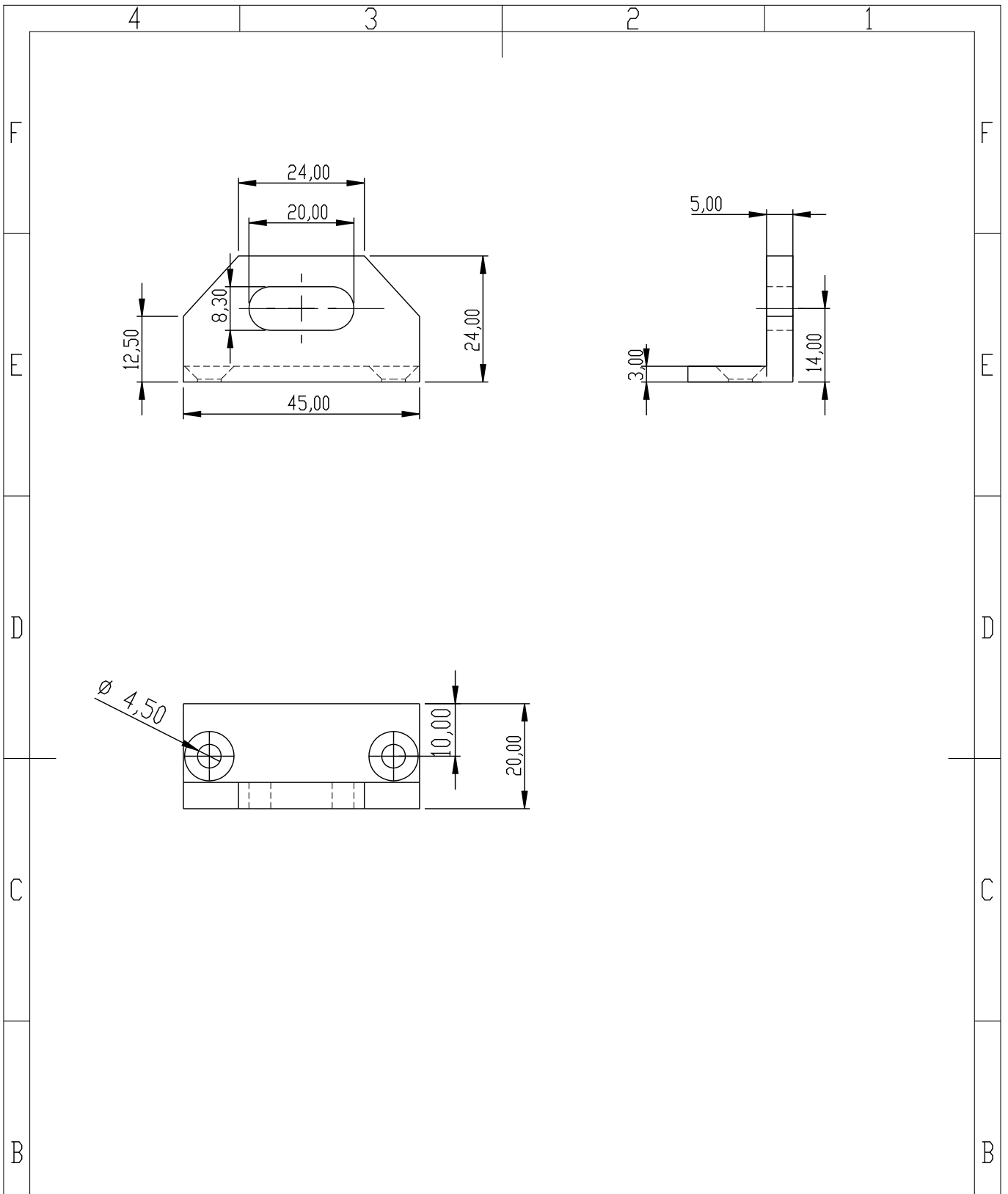

UNLESS OTHERWISE SPECIFIED: DIMENSIONS ARE IN MILLIMETERS SURFACE FINISH: TOLERANCES: LINEAR: ANGULAR:	FINISH:	DEBURR AND BREAK SHARP EDGES	DO NOT SCALE DRAWING	REVISION
---	---------	------------------------------------	----------------------	----------

A		NAME	SIGNATURE	DATE		TITLE:	
	DRAWN						
	CHK'D						
	APPV'D						
	MFG						
	QA						
					MATERIAL: <b>AL7075-T651</b>	DWG NO. <b>Mesa01.P.005-Joint</b>	<b>A4</b>
					WEIGHT:	SCALE:1:1	SHEET 6 OF 14

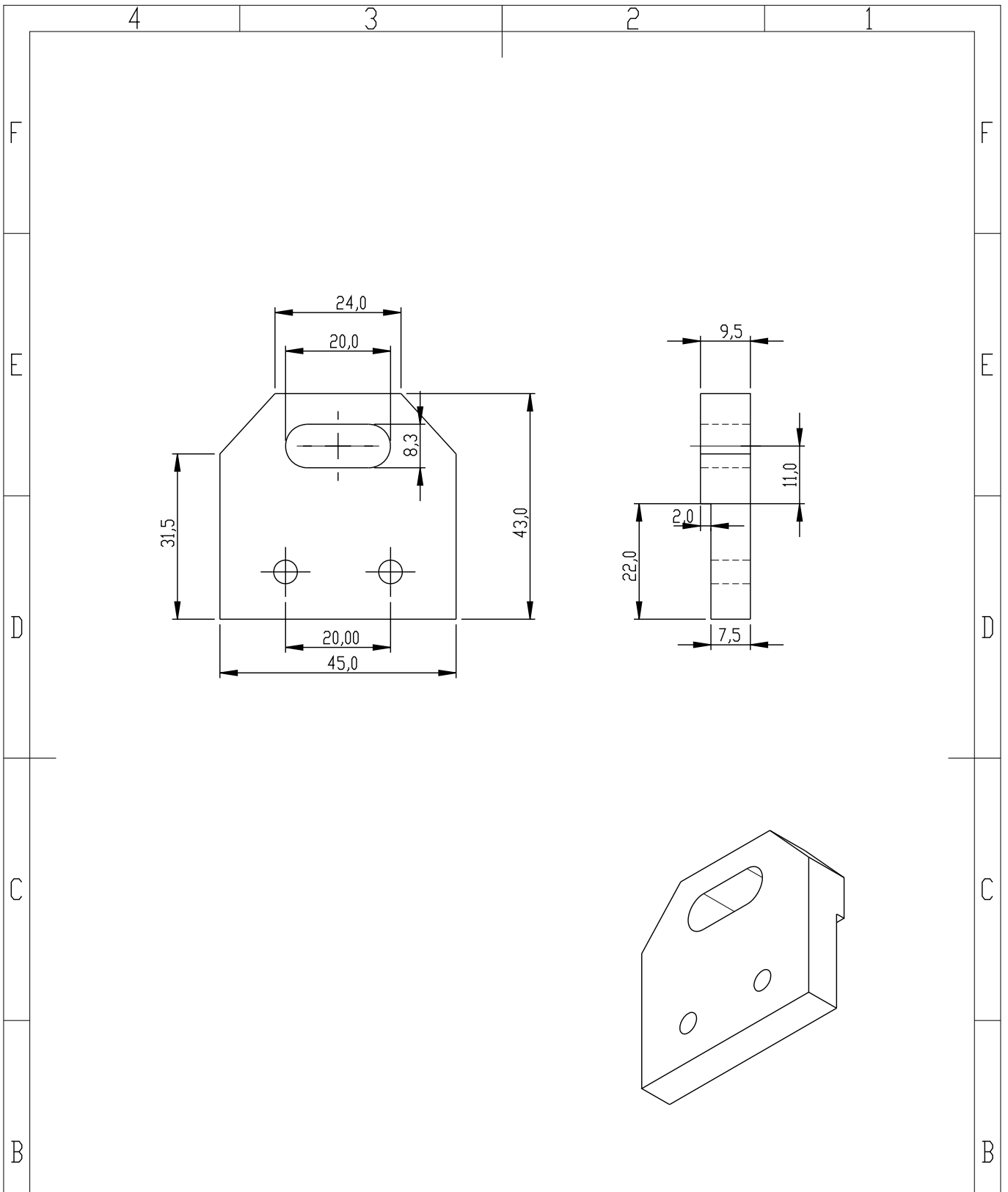

UNLESS OTHERWISE SPECIFIED: DIMENSIONS ARE IN MILLIMETERS SURFACE FINISH: TOLERANCES: LINEAR: ANGULAR:	FINISH:	DEBURR AND BREAK SHARP EDGES	DO NOT SCALE DRAWING	REVISION
---	---------	------------------------------------	----------------------	----------

A		NAME	SIGNATURE	DATE		TITLE:
	DRAWN					
	CHK'D					
	APPV'D					
	MFG					
	Q.A					
	MATERIAL: <b>AL7075-T651</b>				DWG. NO. <b>Mesa01.P.006-Joint</b>	<b>A4</b>
	WEIGHT:				SCALE:1:1	SHEET 7 OF 14



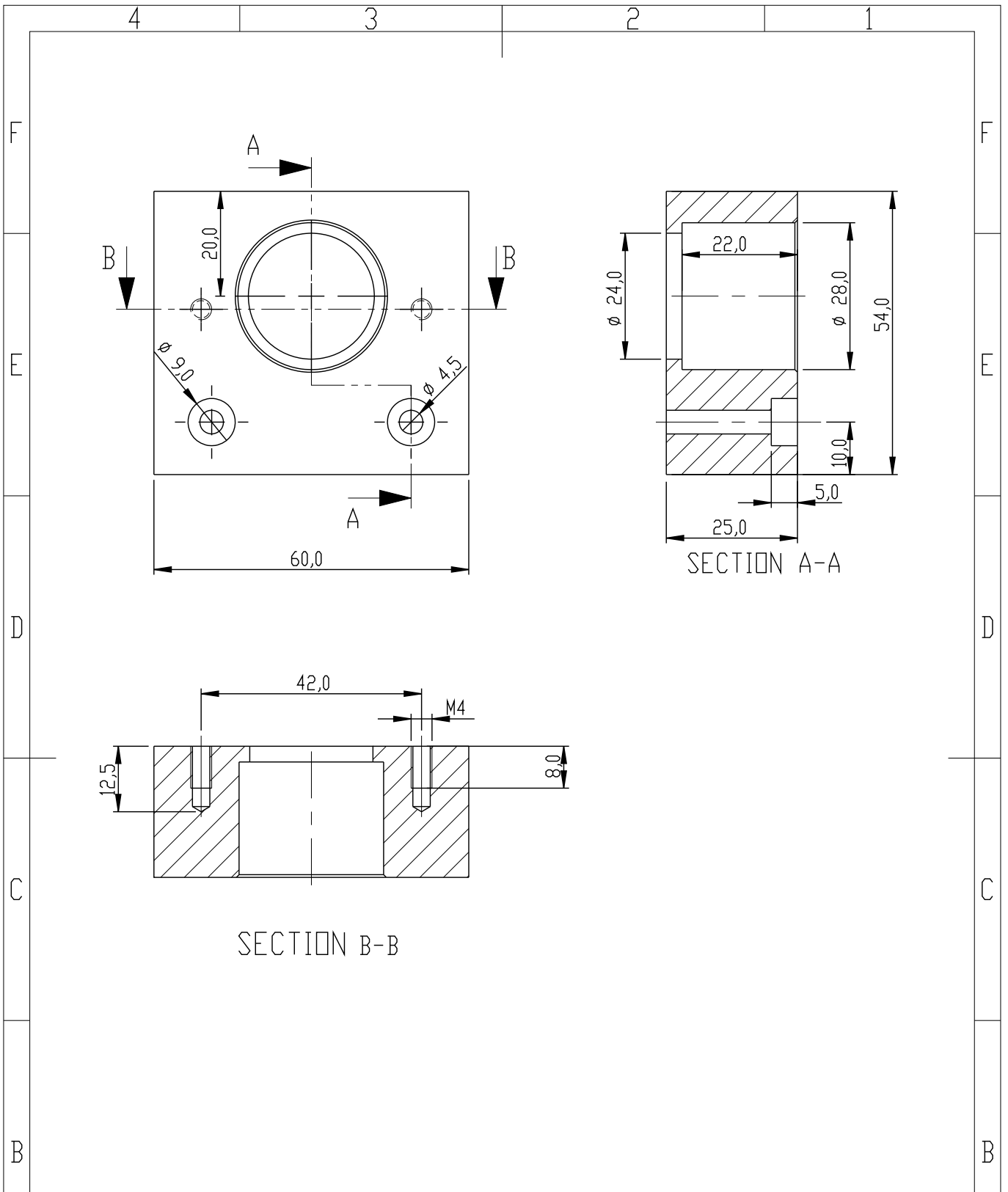

UNLESS OTHERWISE SPECIFIED: DIMENSIONS ARE IN MILLIMETERS SURFACE FINISH: TOLERANCES: LINEAR: ANGULAR:		FINISH:		DEBURR AND BREAK SHARP EDGES		DO NOT SCALE DRAWING		REVISION	
DRAWN		SIGNATURE		DATE		TITLE:			
CHK'D									
APPV'D									
MFG									
Q.A						MATERIAL: Al7075-T651		DWG NO. Caixa-Rolamentos	
						WEIGHT:		SCALE:1:1	
								SHEET 8 OF 14	

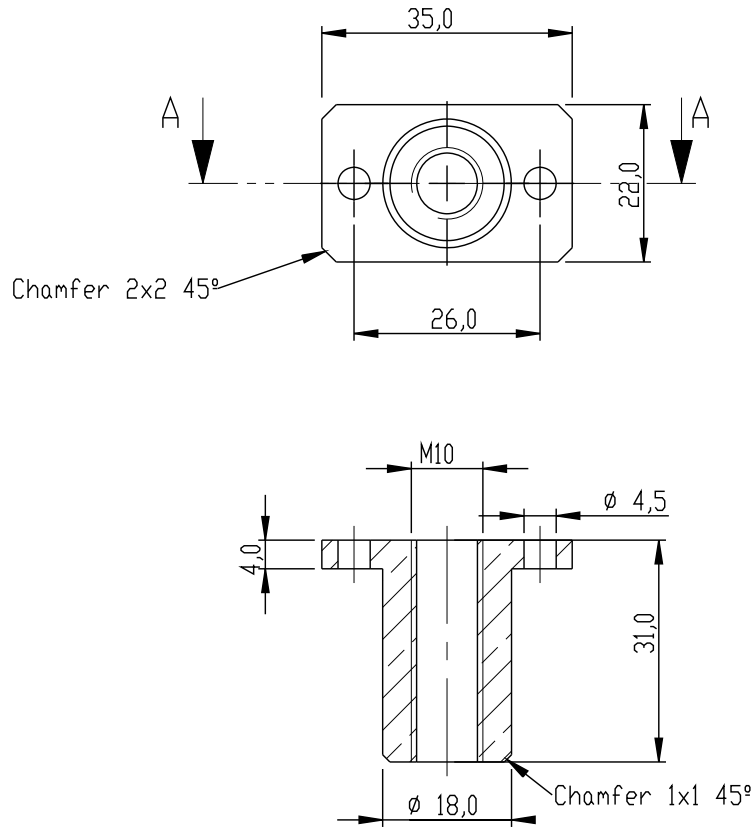

SECTION A-A

UNLESS OTHERWISE SPECIFIED:  
DIMENSIONS ARE IN MILLIMETERS  
SURFACE FINISH:  
TOLERANCES:  
LINEAR:  
ANGULAR:

FINISH:

DEBURR AND  
BREAK SHARP  
EDGES

DO NOT SCALE DRAWING

REVISION

NAME		SIGNATURE	DATE	TITLE:	
DRAWN					
CHK'D					
APPV'D					
MFG					
Q.A				MATERIAL:	DWG NO.
				Bronze Fosforoso	Porca-Casquilho
				WEIGHT:	SCALE:1:1
					SHEET 9 OF 14

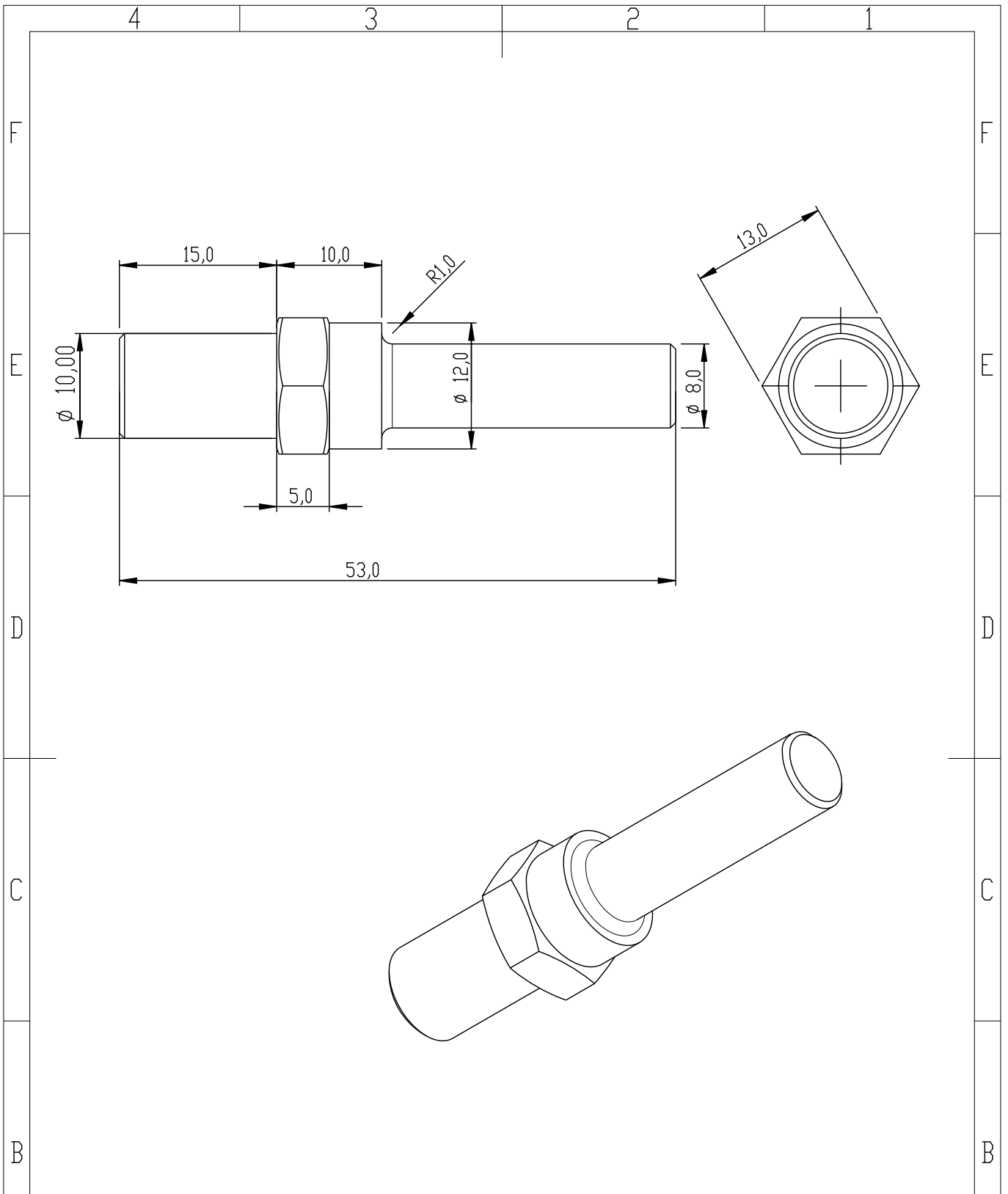

UNLESS OTHERWISE SPECIFIED: DIMENSIONS ARE IN MILLIMETERS SURFACE FINISH: TOLERANCES: LINEAR: ANGULAR:	FINISH:		DEBURR AND BREAK SHARP EDGES	DO NOT SCALE DRAWING	REVISION

A	NAME	SIGNATURE	DATE	MATERIAL: <b>Aço C45</b>	TITLE: <b>Eixo-Tracção</b>	DWG NO. <b>A4</b>
	DRAWN					
	CHK'D					
	APPV'D					
	MFG					
Q.A			WEIGHT:	SCALE:1:1	SHEET 10 OF 14	

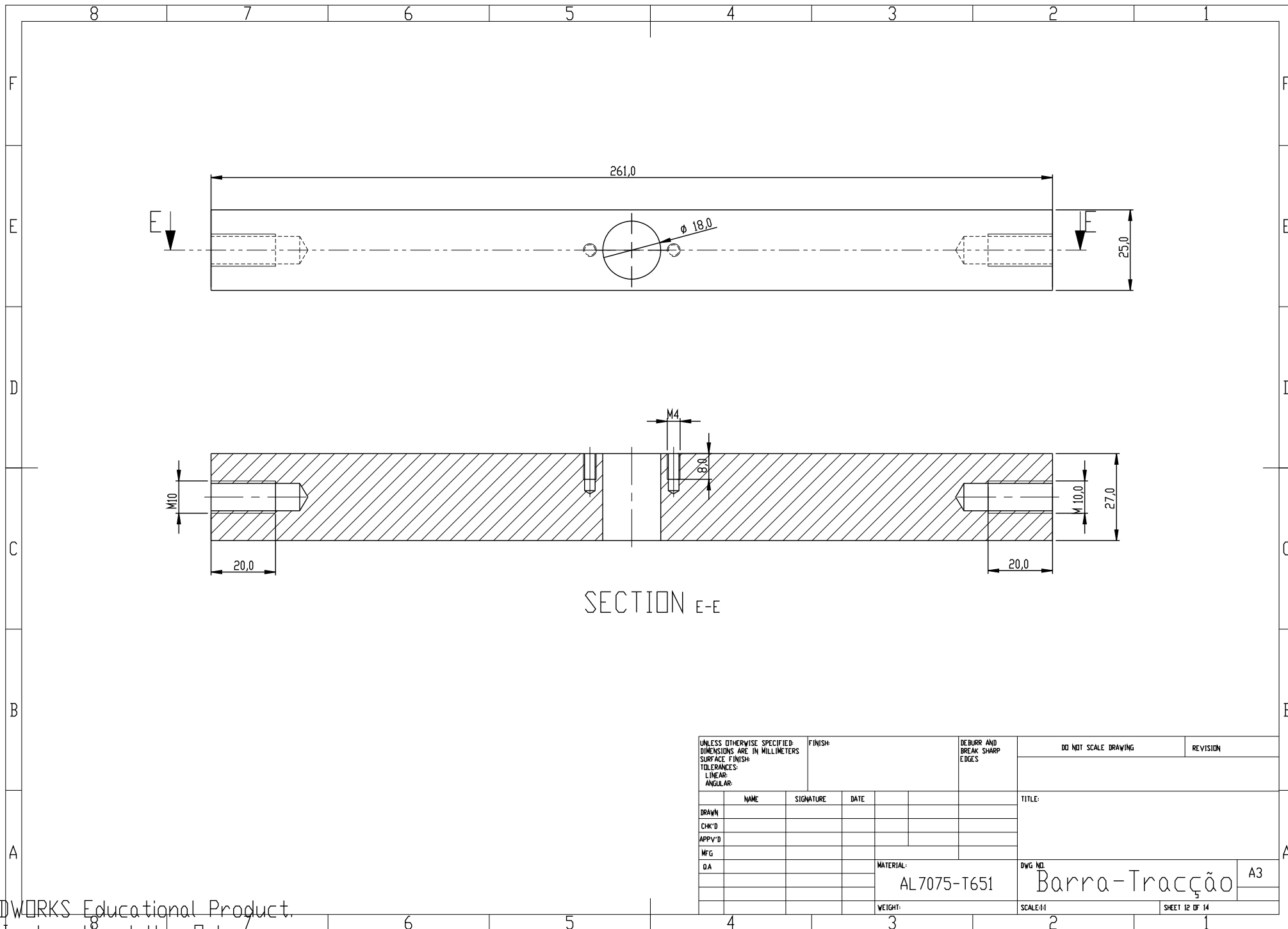

SECTION E-E

UNLESS OTHERWISE SPECIFIED: DIMENSIONS ARE IN MILLIMETERS SURFACE FINISH: TOLERANCES: LINEAR: ANGULAR:				FINISH:		DEBURR AND BREAK SHARP EDGES		DO NOT SCALE DRAWING		REVISION	
DRAWN	NAME	SIGNATURE	DATE					TITLE:			
CHK'D								MATERIAL:			
APP'V'D								AL7075-T651			
MFG								DWG NO. Barra-Tracção			
D.A								SCALE: 1:1			
								SHEET 12 OF 14			
								A3			

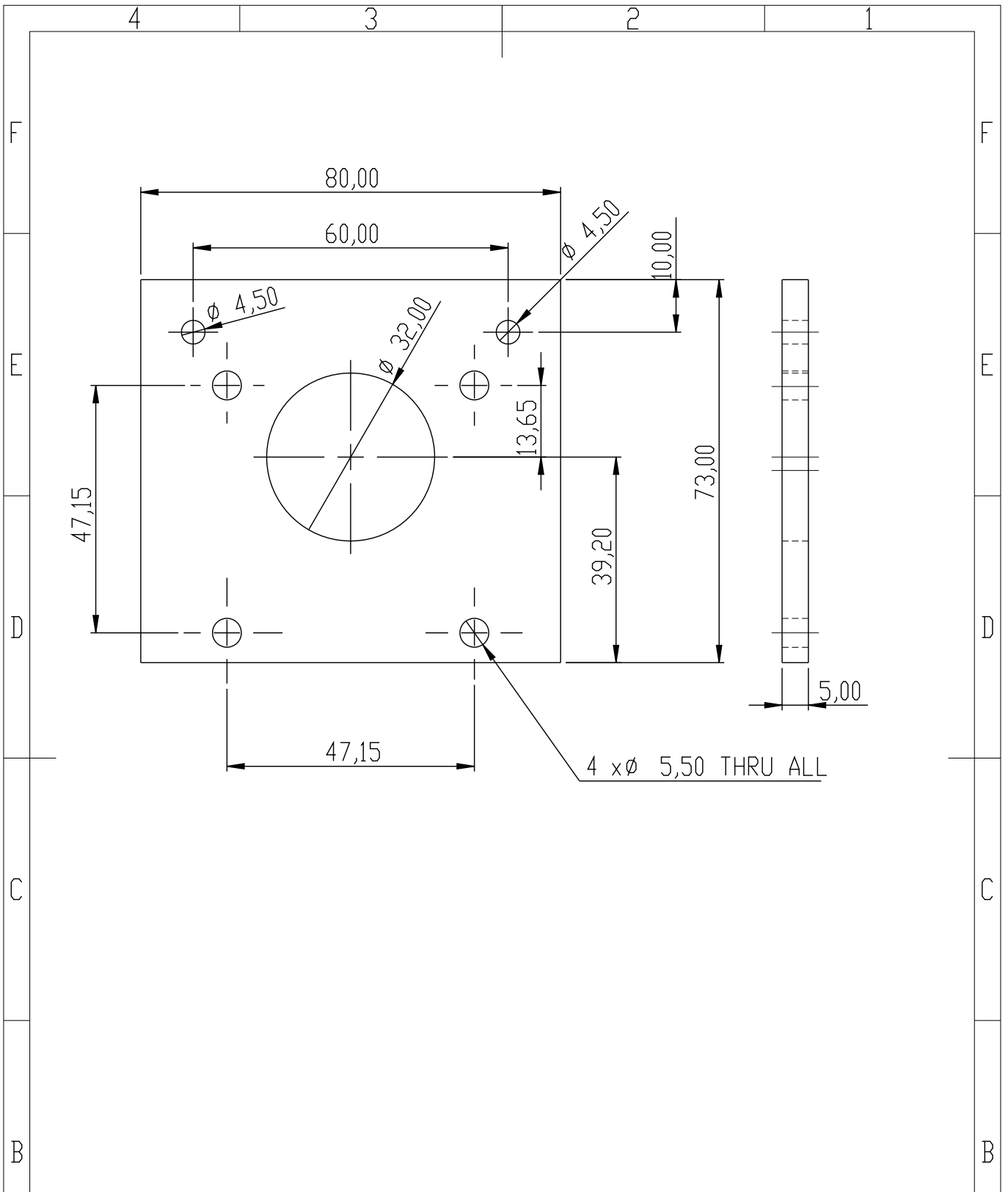

UNLESS OTHERWISE SPECIFIED: DIMENSIONS ARE IN MILLIMETERS SURFACE FINISH: TOLERANCES: LINEAR: ANGULAR:	FINISH:			DEBURR AND BREAK SHARP EDGES	DO NOT SCALE DRAWING	REVISION

A	NAME	SIGNATURE	DATE	MATERIAL: <b>Al7075-T651</b>	TITLE: <b>Chapa-Fixação</b>	DWG NO. <b>A4</b>
	DRAWN					
	CHK'D					
	APPV'D					
	MFG					
	Q.A					
			WEIGHT:	SCALE:1:1	SHEET 11 OF 14	

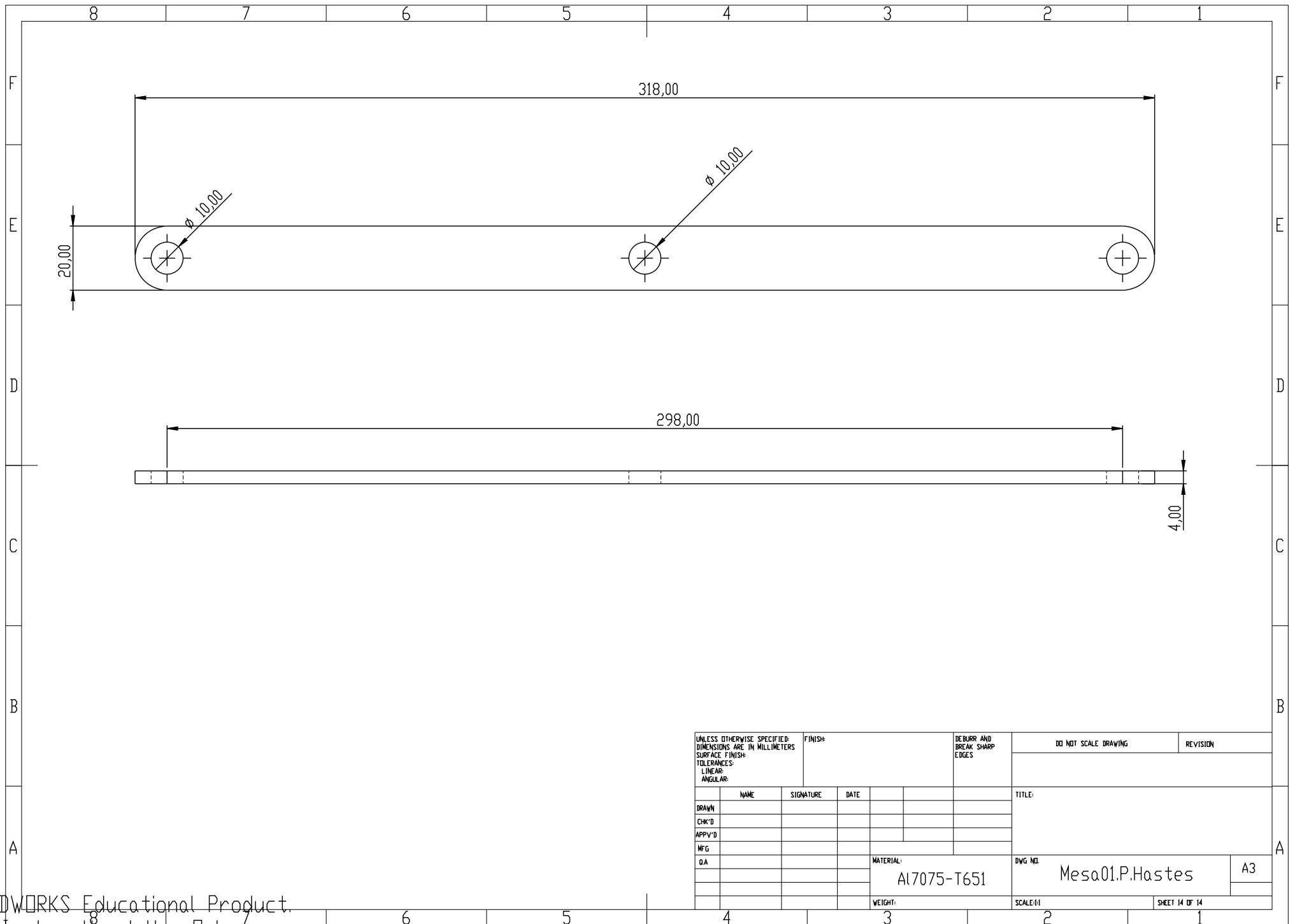

UNLESS OTHERWISE SPECIFIED: DIMENSIONS ARE IN MILLIMETERS				FINISH:		DEBURR AND BREAK SHARP EDGES		DO NOT SCALE DRAWING		REVISION	
SURFACE FINISH:											
TOLERANCES:											
LINEAR:											
ANGULAR:											
	NAME	SIGNATURE	DATE					TITLE:			
DRAWN											
CHK'D											
APPV'D											
MFG											
D.A.								MATERIAL:		DWG NO.	
								A17075-T651		Mesa01.P.Hastes	
								WEIGHT:		SCALE:1:1	
										SHEET 14 OF 14	

SOLIDWORKS Educational Product.  
For Instructional Use Only.